



**NEIGHBOURHOOD ENERGY UTILITY
CONNECTIVITY GUIDELINES &
REQUIREMENTS**

ENGINEERING SERVICES
Neighbourhood Energy Utility
March 2020
Neighbourhood.Energy@Vancouver.ca

TABLE OF CONTENTS

| | | |
|------------|---|-----------|
| 1.0 | GENERAL | 1 |
| 1.1 | INTENT | 1 |
| 1.2 | DISCLAIMERS | 1 |
| 1.3 | DEFINITIONS | 1 |
| 2.0 | INTRODUCTION TO THE NEIGHBOURHOOD ENERGY UTILITY | 2 |
| 2.1 | WHAT IS NEIGHBOURHOOD ENERGY | 2 |
| 2.2 | BENEFITS TO NEIGHBOURHOOD ENERGY | 2 |
| 2.3 | THE FALSE CREEK NEIGHBOURHOOD ENERGY UTILITY | 3 |
| 2.4 | UTILITY OPERATION | 4 |
| 2.5 | UTILITY OWNERSHIP | 5 |
| 2.6 | UTILITY RATES | 5 |
| 2.6.1 | Energy Submetering by Third-Parties | 5 |
| 2.6.2 | Initial Connection Levy..... | 6 |
| 3.0 | TECHNICAL DESCRIPTION OF THE NEU | 6 |
| 3.1 | ENERGY CENTRE | 6 |
| 3.2 | DISTRIBUTION PIPING SYSTEM (DPS) | 7 |
| 3.3 | ENERGY TRANSFER STATION (ETS)..... | 7 |
| 3.4 | NEU SYSTEM OPERATING TEMPERATURES | 11 |
| 4.0 | NEU CONNECTIVITY PROCESS | 12 |
| 4.1 | DEVELOPMENT PERMIT | 12 |
| 4.2 | BUILDING PERMIT (FULL CONSTRUCTION)..... | 13 |
| 4.3 | PRIOR TO COMMENCEMENT OF NEU SERVICE | 15 |
| 5.0 | DIVISION OF RESPONSIBILITY | 16 |
| 5.1 | DEVELOPER'S RESPONSIBILITY | 16 |
| 5.1.1 | Building HVAC and Domestic Hot Water Systems..... | 16 |
| 5.1.2 | Installation and Operational Boundaries..... | 16 |
| 5.1.3 | Preparation for NEU service | 16 |
| 5.1.4 | ETS Commissioning | 17 |
| 5.1.5 | System Operation | 17 |
| 5.2 | NEU'S RESPONSIBILITY | 17 |
| 5.2.1 | NEU Equipment | 17 |
| 5.2.2 | NEU Connectivity Review | 18 |
| 5.2.3 | ETS Commissioning | 18 |
| 6.0 | NEU TECHNICAL REQUIREMENTS AND GUIDANCE | 18 |
| 6.1 | ETS ROOM REQUIREMENTS | 18 |
| 6.2 | NEU CONNECTIVITY REQUIREMENTS | 19 |
| 6.2.1 | Prohibited Equipment | 19 |
| 6.2.2 | Base Building Design Strategies | 19 |
| 6.2.3 | HVAC System Requirements | 20 |
| 6.2.4 | DHW System Requirements..... | 21 |
| 6.2.5 | Electrical, Controls and Communications Requirements | 22 |
| 6.3 | NEU SERVICE REQUIREMENTS | 22 |
| 6.4 | ADDITIONAL GUIDANCE ON ENERGY MODELLING | 22 |
| 7.0 | SUBMITTAL CHECKLIST | 23 |
| 7.1 | DEVELOPMENT PERMIT | 23 |
| 7.2 | BUILDING PERMIT | 23 |
| 7.3 | COMMENCEMENT OF NEU SERVICE..... | 23 |

1.0 GENERAL

1.1 INTENT

This document provides information to assist developers and design professionals to facilitate and optimize connection to the City of Vancouver's Neighbourhood Energy Utility (NEU). Designers are to adopt these technical guidelines and make appropriate provisions in building mechanical, electrical and controls design to enable and to take full advantage of the benefits offered through NEU connection. Requirements for connection to the NEU are outlined.

This document supersedes the following guidance:

- Building Connection Guidelines, January 2016 Update

1.2 DISCLAIMERS

The following information is provided for general use and the user assumes all responsibility. The information contained within is general in nature and does not substitute for the execution of detailed engineering relative to specific projects or problems. The City nor any of their consultants, contractors or employees give any warranty expressed or implied, or assume any legal liability or responsibility for the accuracy, completeness, or usefulness of any information, product application, or process disclosed within this document. Nor are they liable for consequential damage whatever (including, without limitation, damages for loss of business profits, business interruption, loss of business information, or other losses) arising from the use or inability to use this document.

1.3 DEFINITIONS

For the purpose of these guidelines, the following definitions apply:

- CAD: Computer Aided Design
- Delta T (ΔT): Temperature Differential
- DHW: Domestic Hot Water
- DHWS: Domestic Hot Water Supply
- DPS: Distribution Piping System
- EGBC: Engineers and Geoscientists British Columbia
- ETS: Energy Transfer Station
- FCEC: False Creek Energy Centre
- GHG: Greenhouse Gas
- HVAC: Heating, Ventilation, and Air Conditioning
- HWS: Hot Water Supply
- HWR: Hot Water Return
- LEED: Leadership in Energy & Environmental Design
- NES: Neighbourhood Energy System
- NEU: Neighbourhood Energy Utility
- PDF: Portable Document Format

2.0 INTRODUCTION TO THE NEIGHBOURHOOD ENERGY UTILITY

2.1 WHAT IS NEIGHBOURHOOD ENERGY

Neighbourhood Energy Systems (NES), otherwise known as district energy or community energy, are a form of urban infrastructure that supplies energy (heating, cooling, electricity, or a combination of the three) to buildings connected to a network within a designated service area. Such systems typically consist of a centrally located energy generation facility, a distribution piping network, and energy transfer equipment located at the serviced buildings. These systems are particularly well-suited to dense urban settings with a mix of building uses, such as multi-unit residential, commercial and office uses, as there are opportunities for energy sharing between buildings that require energy at different times of the day and the year.

Depending on the local context, NES providing centralized heating can significantly displace the use of fossil fuels for heat production in buildings. NES can leverage economies of scale to incorporate renewable energy sources such as geo-exchange, solar, biomass or waste heat recovery, and are operated professionally for greater energy efficiency. The result is reduced greenhouse gas (GHG) emissions associated with generating heat and hot water for buildings.

Around the world, NES are gaining momentum as an important urban energy strategy that can effectively address growing concerns about climate protection, energy security and economic resiliency at the urban scale.

The City of Vancouver owns and operates an NES for district heating, the False Creek Neighbourhood Energy Utility, known as the NEU.

2.2 BENEFITS TO NEIGHBOURHOOD ENERGY

There are many benefits to connecting to an NES.

Environmental Benefits: NES provide economies of scale and flexible infrastructure that can adapt to using a wide variety of renewable and waste energy options that would otherwise not be available to an individual building heating system. The heating of buildings generates more than half of our City's greenhouse gas emissions, and the use of renewable energy-based NES results in substantial emission reductions.

Social Benefits: NES support the use of radiant hot water heating systems in buildings which provide customers with a higher level of comfort at a lower energy use, as compared to conventional space heating options.

Economic Benefits: NES's are typically self-funded utilities that provide substantial GHG reductions. Through NES use of local and renewable energy sources and flexibility to adapt to future energy technologies, it is anticipated that NES customers typically enjoy rate stability that outperforms conventional options. In addition, NES can help building owners meet the energy efficiency and green building targets more cost effectively as compared to the use of distributed stand-alone green energy options.

For developers, connecting to an NES means reduced capital costs associated with designing and constructing a heat generation system for a building. This also reduces the space requirement dedicated to heating equipment, as the Energy Transfer Stations (ETS) are much more compact compared to traditional heating systems.

For customers, connecting to an NES removes the need for building strata corporations or building managers to run the heating equipment efficiently, stay on schedule with important maintenance activities, or budget for maintenance and replacement costs. NES are professionally managed and operated to provide cost-effective and stable rates to its customer base through a regulated rate-setting process. Further, the scale of NES operations creates opportunities to use locally available energy sources that are otherwise not economically feasible for individual buildings. This has the benefit of reducing ratepayers' exposure to fluctuations in electricity and natural gas prices.

2.3 THE FALSE CREEK NEIGHBOURHOOD ENERGY UTILITY

The NEU began operation in 2010 to provide low-carbon space heating and hot water to the Olympic Village and its surrounding area. The False Creek Energy Centre (FCEC), located at 1890 Spyglass Place in Vancouver, is an energy generation and distribution plant that recovers waste heat from sewage and generates heat from gas-fired boilers for peaking and back-up conditions. As of 2020, the NEU serves Southeast False Creek, parts of Mount Pleasant and the Great Northern Way Campus lands, and is planned to expand into Northeast False Creek and the False Creek Flats as part of a Council-approved expansion framework approved in 2018. Refer to the [NEU website](#) for the current utility service area.

The NEU does not provide cooling as an energy service to individual buildings. However, as some buildings may have significant mechanical cooling requirements, there may be opportunity for the NEU to accept waste heat from building cooling loads. If the Developer is considering this option please discuss with the NEU Engineer at the earliest opportunity.

2.4 UTILITY OPERATION

The NEU generates heat at the False Creek Energy Centre (see Figure 1) and distributes the energy to buildings within the service area through the following steps described below. Refer to Section 3.0 for the detailed technical description of the system.

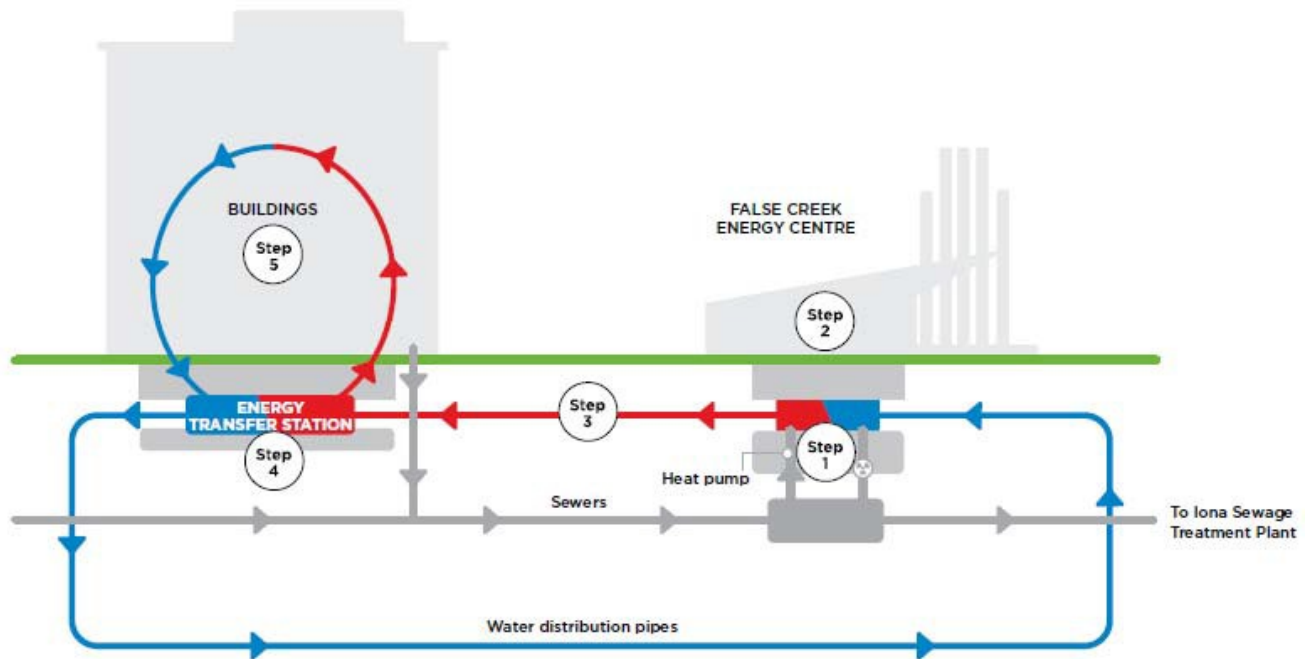

Figure 1: The NEU System Components

Step 1:

The False Creek Energy Centre is co-located with a City of Vancouver sewage pump station. Thermal energy (heat) is captured from sewage using heat pump technology. The warm wastewater in the City's sewage system provides a source of heat intended to supply 70% of the utility's annual energy needs.

Step 2:

The Energy Center is also equipped with natural gas boilers, which provides the remaining 30% of the heat required on colder days of the year.

Step 3:

A Distribution Piping System (DPS) conveys thermal energy – in the form of heated water – from the False Creek Energy Centre through underground piping to the buildings that it services.

Step 4:

Each building has an Energy Transfer Station (ETS) that transfers the thermal energy (heat) to the building's mechanical system. The NEU charges its customers based on the amount of energy exchanged at the ETS.

Step 5:

The building's mechanical system then distributes heat and hot water to building occupants at the point of use.

2.5 UTILITY OWNERSHIP

The NEU is a self-funded utility that operates on a commercial utility model. It provides a return on investment to the City while providing cost-competitive rates to its customers.

The City owns and operates the NEU with direct control over investment decision making, rate setting and GHG performance targets. Given the City's dual role as owner and regulator of the utility, Council established the Neighbourhood Energy Expert Panel to provide advice and input on issues including customer rate setting, policy and expansion opportunities. To ensure fair and appropriate rates, all annual rate changes are reviewed by the independent Expert Panel and approved by Council.

2.6 UTILITY RATES

NEU customers are billed according to a tariff established for 3 different customer classes based on building type and location, similar to the practices of other utilities in British Columbia. A utility bill from the NEU to a customer building will typically consist of two line items, or charges:

- Monthly Energy Charge
- Monthly Capacity Levy

The Monthly Energy Charge is a variable fee based on the amount of metered heat energy used in the customer building each month. The Energy Charge is intended to cover variable costs, which are mainly fuel costs for the NEU and some variable operating costs.

The Monthly Capacity Levy is a fixed monthly fee related to the customer building's capacity requirements. The Monthly Capacity Levy is intended to cover NEU fixed costs (such as fixed capital and operating costs). There are two forms of this levy:

- Floor Area Levy – This rate is applied to Class 1 customers, which are residential and mixed-use buildings within Southeast False Creek, and is based on the connected floor area.
- Peak Capacity Levy – This rate is applied to Class 2 (residential and mixed used buildings outside of Southeast False Creek) and Class 3 (non-residential buildings). This levy is based on an estimate of the energy capacity required and subscribed by the customer building (based on the building's design) and subject to approval by the NEU Engineer.

For connected buildings that contribute building-generated waste heat to the NEU distribution system, a credit to the utility bill is provided based on the amount of thermal energy sent back to the NEU.

Refer to the *Energy Utility System By-Law No. 9552, Schedule C* for current energy rates.

2.6.1 Energy Submetering by Third-Parties

The rates described in Section 2.6 are invoiced by the NEU based on the customer building's monthly metered energy consumption measured at the ETS, plus the applicable monthly capacity levy. Depending on the building, a strata corporation or management company may opt to engage third-party companies to install additional sub-metering equipment and to manage suite-level billing. The City of Vancouver does not have control or oversight on any additional service fees that may be levied by these third parties or how NEU fees are represented by third-parties.

For submetered buildings, it is recommended that the NEU Monthly Capacity Levy be accounted for as part of the base building operational budget. This levy is analogous to the costs associated with operating, maintaining and replacement of heating and domestic hot water (DHW) systems in buildings not connected to the NEU. Submetered energy charges to individual building suites are recommended to be based solely on monthly energy consumption by each suite.

2.6.2 Initial Connection Levy

Developers connecting to the NEU are required to pay an Initial Connection Levy for the NEU to recover the cost of connecting new buildings. This is similar to the use of connection fees for waterworks and sewer utilities and is also a standard practice in the energy utility sector. Many new buildings in Vancouver are required to meet strict GHG performance limits through the Zero Emissions Building Plan. By connecting to the NEU, developers can reduce costs related to the building's mechanical and envelope systems while meeting the obligations of the Zero Emissions Building Plan. This Levy helps distribute these cost savings between the developer and the NEU customer, by lowering the capital funding requirements for the NEU connection which leads to lower long-term energy costs for NEU customers.

The Initial Connection Levy consists of two parts:

- A Fixed Portion – this is intended to recover the cost of the connection pipe, which is influenced by physical factors such as distance from the NEU distribution network, road type adjacent to the building, etc.
- A Variable Portion – this is intended to recover the cost of the energy transfer interface, which is directly impacted by the amount of peak energy demand required for the building.

Refer to the *Energy Utility System By-Law No. 9552, Schedule C* for the most current energy rates.

3.0 TECHNICAL DESCRIPTION OF THE NEU

3.1 ENERGY CENTRE

The False Creek Energy Centre (FCEC) contains the major heat production equipment for the NEU, including sewage heat recovery heat pumps and natural gas boilers, and associated pumping and controls equipment. As of 2019, the base heating load for the NEU system is met by 3 MW of waste heat recovery from sewage, with peak loads and back-up provided by renewable and conventional natural gas. The current renewable energy target for the NEU system is 70% from renewable energy.

As the NEU expands, both renewable energy and natural gas capacity will be added at FCEC and at new satellite energy production centres. As part of Vancouver's Climate Emergency Response, the NEU is evaluating opportunities to achieve 100% of its energy from renewable sources before 2030.

3.2 DISTRIBUTION PIPING SYSTEM (DPS)

The NEU DPS is a closed loop two-pipe hot water distribution network providing separate supply and return loop hot water. The water is heated at the False Creek Energy Center and circulated to buildings within the NEU service area. The DPS comprises pre-insulated steel piping buried in City streets along with other utilities.

3.3 ENERGY TRANSFER STATION (ETS)

Each customer building will house an ETS that is owned by the NEU. The ETS is typically mounted on a skid and includes the following key components (see Figure 2):

- NEU supply and return piping from the building penetration
- Heat exchangers to transfer heat to the building's hydronic heating and DHW system
- Controls and a Control Panel to regulate the flow required to meet the building's energy demand and to maintain NEU return temperatures
- An energy meter to monitor the energy consumed by each building for billing and system optimization purposes.

Typically, there are two heat exchangers in each ETS, one for space heating and one for domestic water heating. Figure 3 shows the schematic of a typical ETS. The ETS will be located in the ETS Room of the customer building.

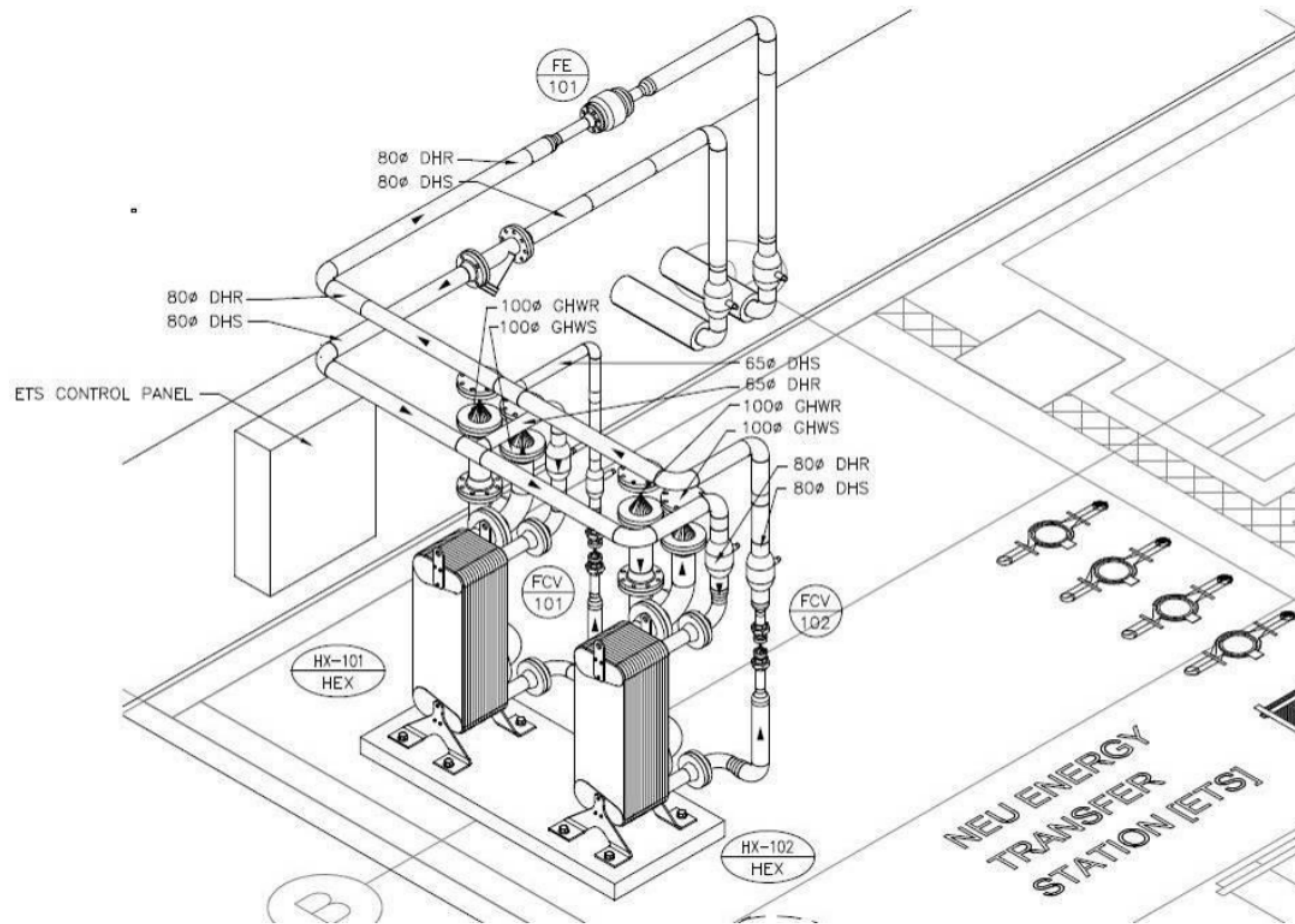

Figure 2: Typical ETS Configuration

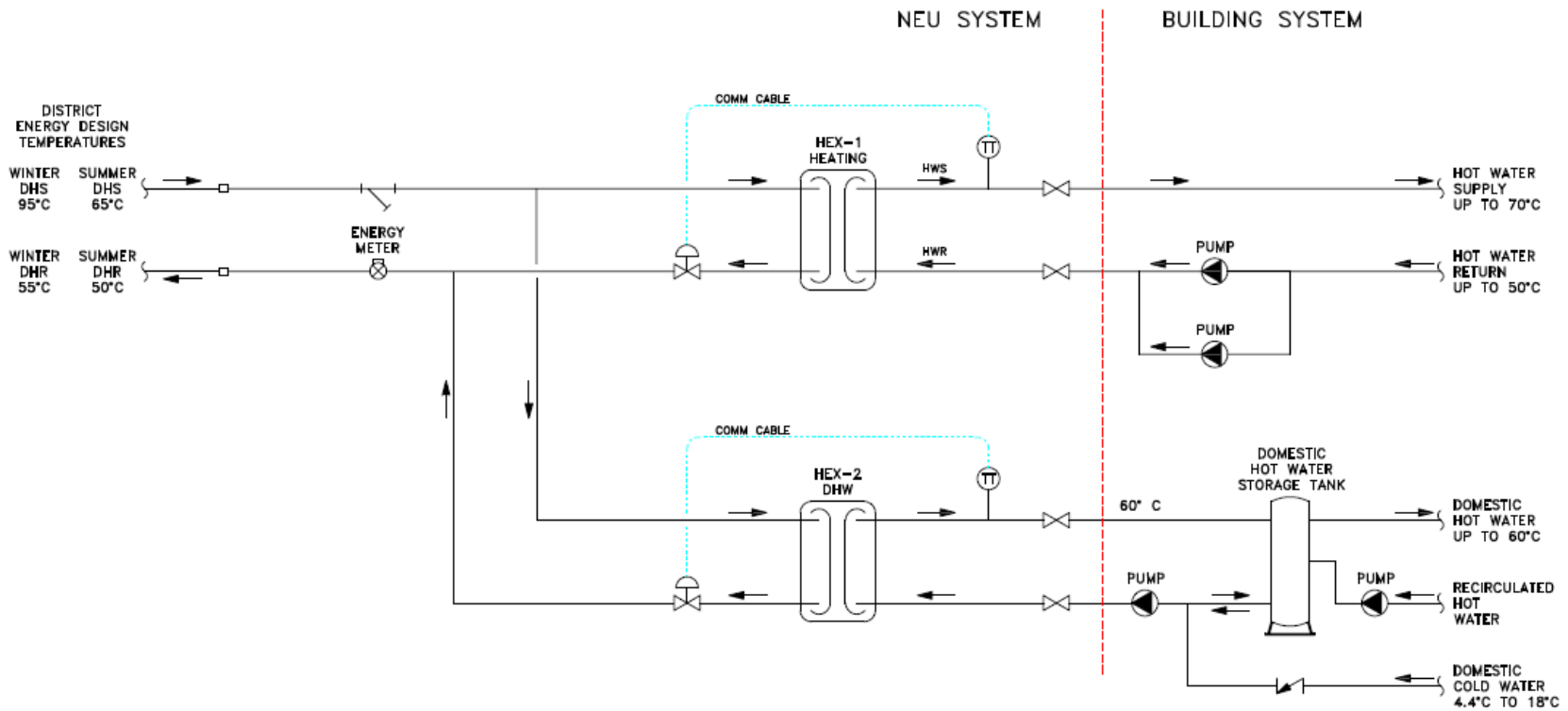

Figure 3: Typical ETS Schematic and Building Connection

3.4 NEU SYSTEM OPERATING TEMPERATURES

The NEU system operates at the temperatures shown in Table 1. The NEU supply temperature fluctuates based on outdoor air temperature but is never less than 65°C. As the outdoor air temperature drops, the NEU supply temperature will increase as shown in Figure 4. Figure 4 also shows the required design parameters for the building side heating system for compatibility with the NEU system.

Table 1: NEU System Operating Temperatures

| | NEU Design Condition | | Building Space Heating System Design Condition | | Building Domestic Hot Water System Design Condition | |
|------------------------------------|----------------------|--------|--|--------|---|--------|
| | Winter | Summer | Winter | Summer | Winter | Summer |
| Max. Supply Temperature (°C) | 95 | 65 | 70 | 50 | 60 | 60 |
| Max. Return Temperature (°C) | 55 | 50 | 50 | 30 | 4.4 | 18 |
| Min. Temperature Differential (°C) | | | 20 | 20 | | |

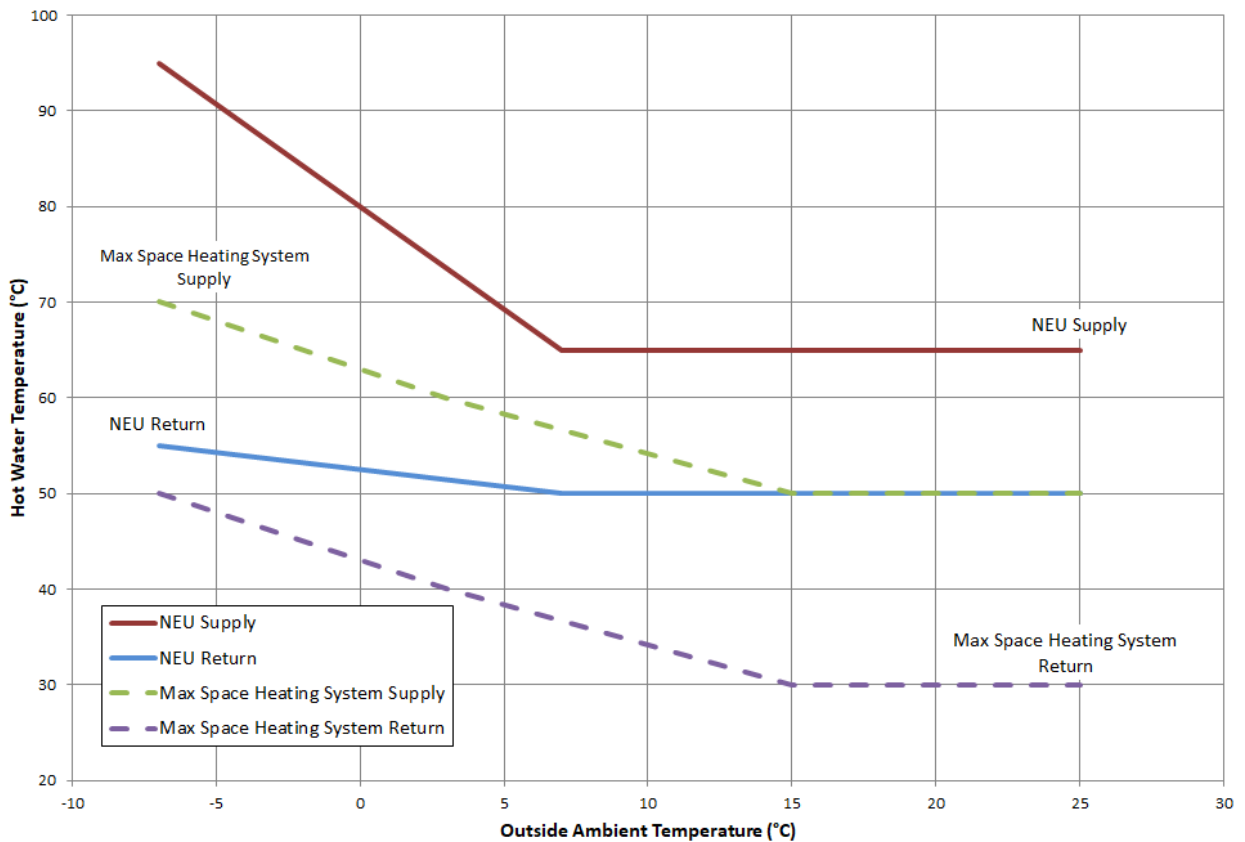

Figure 4: NEU System and Building Heating System Temperatures

4.0 NEU CONNECTIVITY PROCESS

For buildings connecting to the NEU, the Developer must take additional steps to obtain NEU approvals through the City’s regular Development and Building Permitting processes to initiate NEU service.

4.1 DEVELOPMENT PERMIT

The NEU Review Process at Development Permit is presented in Figure 5 below. Prior to issuance of Development Permit, the ETS Room Requirements (Section 6.1) must be confirmed as met by the NEU Engineer.

- If an alternate ETS Room location is required by the Developer, the Developer is required to commit to the payment of increased costs as estimated by the NEU Engineer.

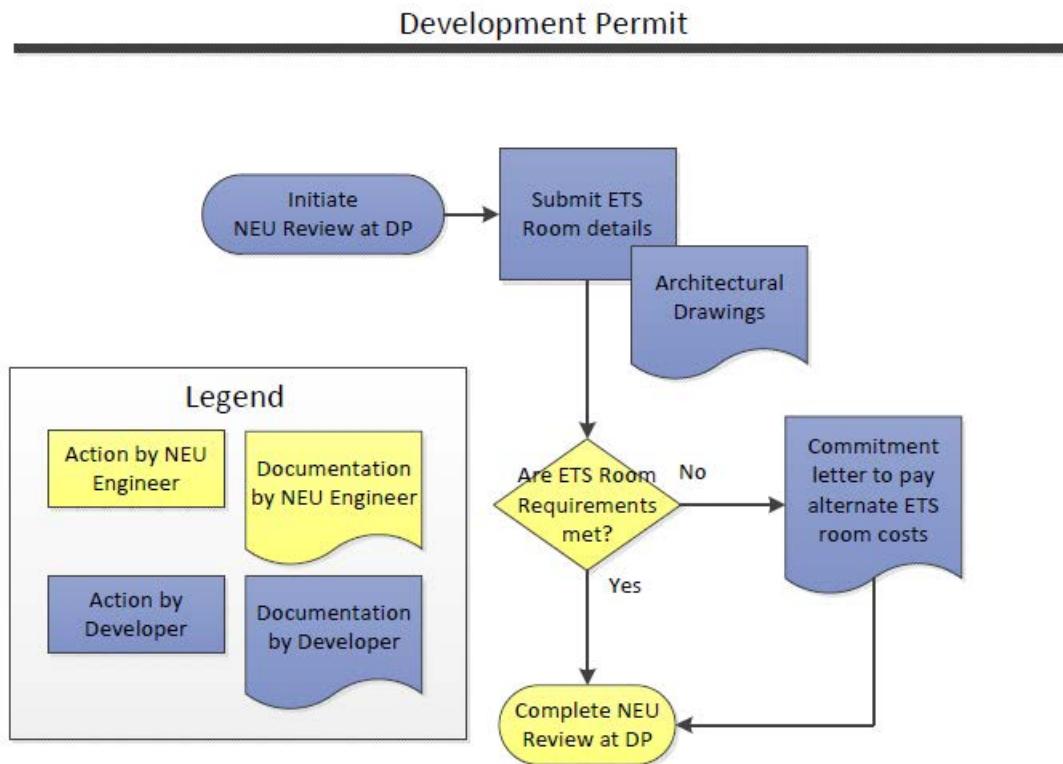

Figure 5: NEU Review Process at Development Permit

4.2 BUILDING PERMIT (FULL CONSTRUCTION)

The NEU Review Process at Building Permit is presented in Figure 6 below. Prior to issuance of the Full Construction Building Permit, the NEU Engineer will provide a Connectivity Review of the building design to confirm the NEU Connectivity Requirements (Section 6.2) are met.

- Upon receipt of the Application for Thermal Energy Service from the Developer, the NEU Engineer will initiate the NEU Connectivity Review. This review typically takes a minimum of 2 months to complete, and may be completed prior to the release of a staged Building Permit (Full Structure). In some instances, this Review process may be extended and deferred to the Building Permit (Full Construction) stage, upon agreement with the NEU Engineer.
- During this Review, there is one round of information exchange and one in-person meeting (as needed). The NEU Engineer will provide a Review Memo to the Developer for confirmation of the review.
- Prior to the issuance of the full Building Permit, the Developer must pay the Initial Connection Levy (see Section 2.6.2) and, if applicable, any estimated costs of the alternate ETS Room location.

Building Permit

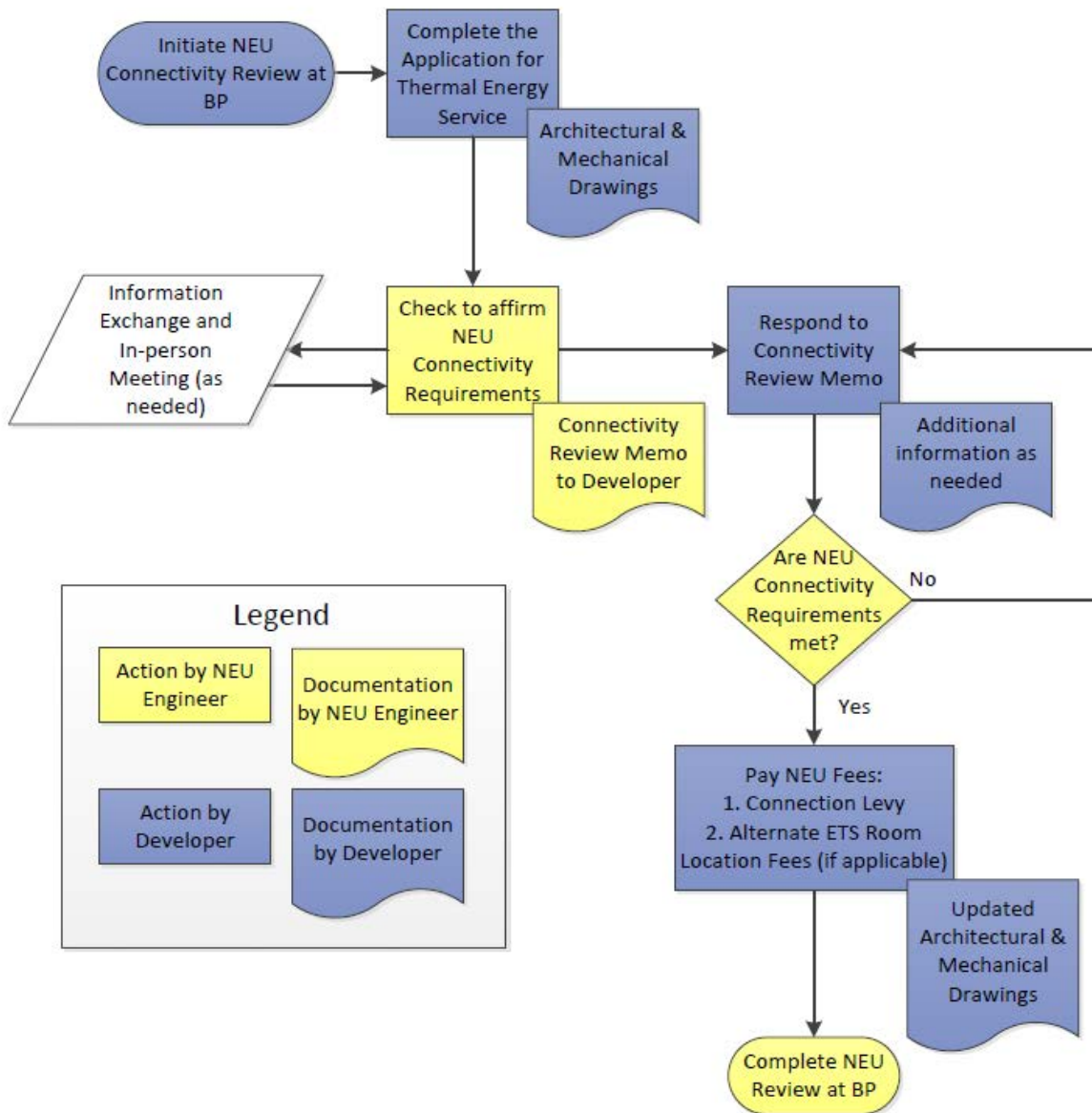

Figure 6: NEU Review Process at Building Permit

4.3 PRIOR TO COMMENCEMENT OF NEU SERVICE

The NEU Review Process prior to commencement of NEU service is presented in Figure 7 below. Prior to start-up of the NEU service to the building, the NEU Service Requirements (Section 6.3) must be confirmed as met by the NEU Engineer.

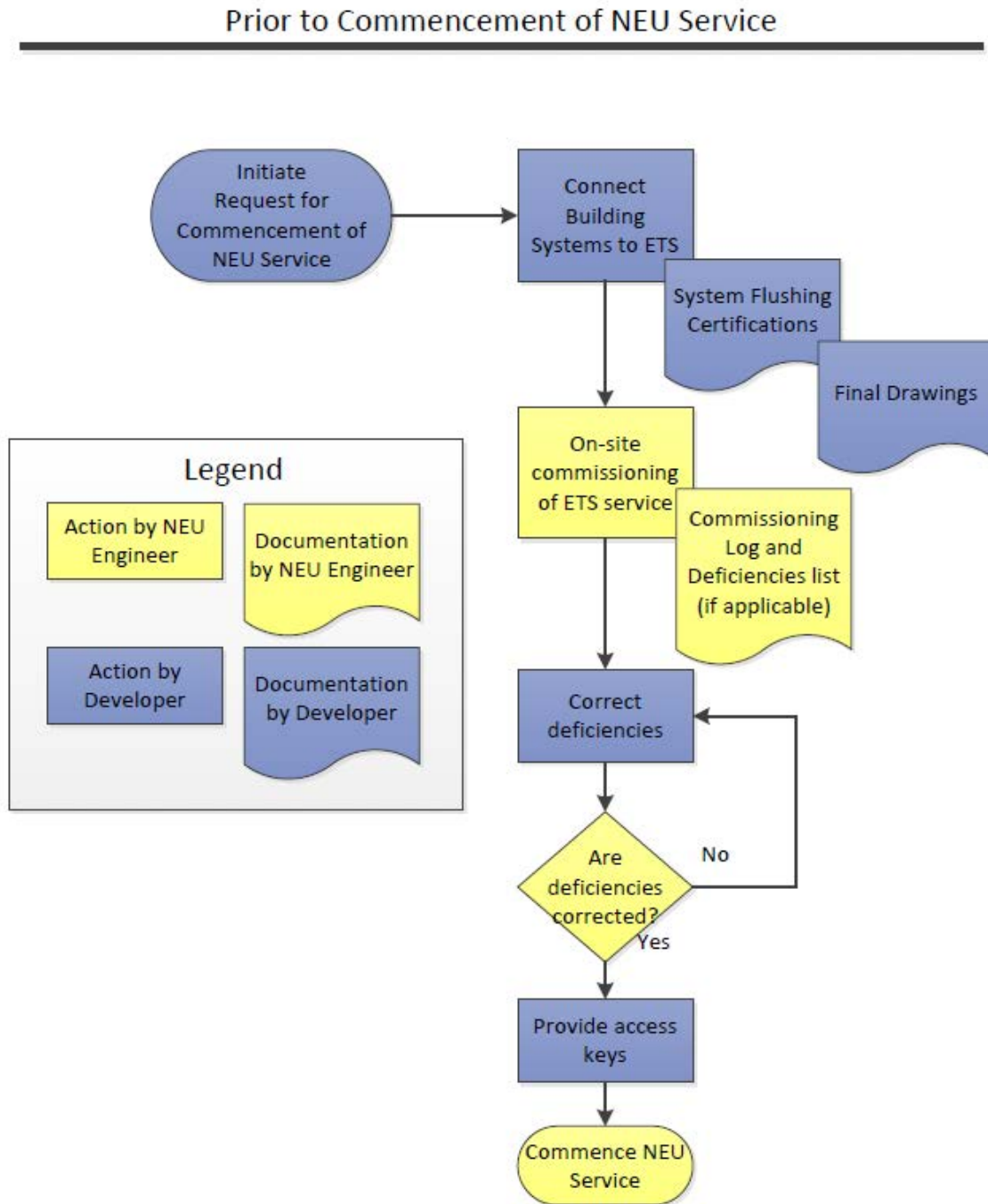

Figure 7: NEU Review Process prior to Commencement of NEU Service

5.0 DIVISION OF RESPONSIBILITY

This section provides information on the delineation of responsibilities between the Developer and the NEU to ensure coordination and seamless integration between the customer building and the NEU.

5.1 DEVELOPER'S RESPONSIBILITY

5.1.1 Building HVAC and Domestic Hot Water Systems

The Developer is responsible for designing, installing and operating the customer building's HVAC and domestic hot water (DHW) systems. The Developer is responsible for designing the building systems to operate efficiently with the NEU system by following the NEU Connectivity Requirements (Section 6.2).

The building space heating shall be designed with hydronic thermal distribution systems, including components such as:

- Internal distribution pumps
- Internal distribution piping
- Heating elements, e.g. fan-coil units, air handling unit coils, perimeter heating, etc.

All of the building space heating and DHW demand is to be supplied by the NEU, except as permitted by the *Energy Utility System By-Law No. 9552, Section 5.2*.

The Developer shall provide a dedicated ETS Room for the location of the ETS and for the penetration of the branch lines from the exterior NEU distribution piping.

The Developer will provide the building design information required by the NEU to conduct a Connectivity Review of the design to confirm the NEU Connectivity Requirements as part of the Building Permit review process.

It is the responsibility of the Developer to ensure that any future tenant improvement spaces are configured so they can easily integrate into the building's space heating and DHW systems serviced by the NEU.

5.1.2 Installation and Operational Boundaries

The Developer is responsible for all piping and other components necessary to connect the hydronic heating and DHW systems to the building side of the ETS at the demarcation point (see Figure 4). The demarcation point is typically at the first valve on the building side of the ETS heat exchangers.

5.1.3 Preparation for NEU service

The Developer shall work closely with the NEU Engineer to determine the optimal location of building foundation penetration necessary for the NEU supply and return piping. The preferred method for new construction is to core holes for the supply and return pipes at the time of service connection. This is to ensure efficient piping layout within the ETS Room.

The Developer is responsible for coring and proper sealing of the building envelope.

The Developer is to ensure that the NEU distribution piping route, both inside and outside the building, is accessible and free of obstacles to facilitate piping installation.

The Developer shall provide the NEU with access to the ETS Room as described in the *Energy Utility System By-Law No. 9552, Section 6*.

The Developer is responsible for facilitating controls and communication from the building management system (if applicable) to the NEU Panel, and from the NEU Panel to the NEU operations system via antenna, internet or fibre optic communications, as determined by the NEU Engineer.

5.1.4 ETS Commissioning

The Developer is responsible for flushing the building's hot water systems prior to the commissioning of the ETS by the NEU Engineer and NEU Operators. Note that flushing through the ETS heat exchangers is not permitted; the ETS must be bypassed with spool pieces during the flush. The Developer is responsible for coordinating the on-site commissioning of the ETS with the NEU Engineer and all relevant trades.

After commissioning and prior to the commencement of ETS Service, the Developer is responsible for correcting any deficiencies noted by the NEU Engineer. Any changes made to the building's hot water systems after commissioning that may impact NEU performance shall be reported to the NEU Engineer. The Developer shall provide the NEU Engineer with all necessary keys or access fobs to the ETS Room prior to commencement of NEU service.

5.1.5 System Operation

The Developer shall design appropriate ventilation and maintain the ETS Room at a temperature between 10°C to 35°C.

The Developer is responsible for ensuring building heating water system quality meets the NEU Engineer's specifications. Refer to the water quality specifications outlined in *Energy Utility System Bylaw No. 9552 Schedule B*.

5.2 NEU'S RESPONSIBILITY

5.2.1 NEU Equipment

The NEU is responsible for the design, installation, operation and maintenance of the ETS at the ETS Room. The location of the ETS Room is agreed upon between the NEU Engineer and the Developer at the Development Permit Stage.

The NEU is responsible for the installation, ownership, and maintenance of the primary distribution pipes inside the building up to the supply side of the ETS. The NEU will provide the branch connections necessary from the NEU main trunk lines into the building.

Note that if the ETS Room is not located near the location where the NEU distribution pipes penetrate the building, the Developer shall be responsible to pay for the estimated increased piping costs (see Section 6.2).

The NEU is responsible for servicing the energy metering equipment.

The NEU provides temperature transmitters, pressure and temperature gauges, thermowells, control valves, energy meters, and a control panel as part of the ETS package. Temperature transmitters for the secondary side of the ETS heat exchangers are also provided. This allows the NEU Engineer to remotely monitor every ETS and control the building side of the heating and DHW systems, and allows alarms to be transmitted to NEU staff on a 24-hour basis.

5.2.2 NEU Connectivity Review

The NEU Engineer will provide a Connectivity Review of the customer building's HVAC design during the Building Permit review stage to confirm that NEU Connectivity Requirements have been met. The NEU is not responsible for the design of the customer building's mechanical system; this is the responsibility of the Engineer of Record. During the Connectivity Review, the NEU Engineer will provide suggestions as necessary for optimizing the building's connection to the NEU.

As per guidance provided by Engineers and Geoscientists BC "[Practice Note 16: Professional Design and Field Review by Supporting Registered Professionals, February 2017](#)", the NEU Engineer can provide (upon request) the Registered Professional of Record (typically the Mechanical Engineer of Record) with the following schedules to affirm Code compliance for the Energy Transfer Station installed within the building:

- Schedule S-B Assurance of Professional Design and Commitment for Field Review by Support Registered Professional; and
- Schedule S-C: Assurance of Professional Field Review and Compliance by Supporting Professional.

5.2.3 ETS Commissioning

The NEU Engineer, together with the Developer's team, will commission the ETS at the agreed-upon time to be arranged by the Developer. The NEU Engineer will provide a Commissioning Log with a list of any deficiencies that need to be corrected prior to commencement of ETS service.

6.0 NEU TECHNICAL REQUIREMENTS AND GUIDANCE

This section provides the technical requirements and best practices to optimize the NEU and building system efficiency, and to provide seamless integration with the NEU. Developers are required to make provisions in building design to take full advantage of the benefits provided by the NEU. Guidance on how design professionals can account for NEU connection in their building energy models for the purposes of Code Compliance and/or LEED certification are provided in brief.

6.1 ETS ROOM REQUIREMENTS

The following requirements are verified prior to the release of the Development Permit and re-confirmed prior to the release of the Building Permit.

Location

- The ETS Room shall be located on the building first sub-level (generally used as parkade level P1), adjacent to the building perimeter, in a secure location convenient for NEU distribution pipes to enter the building approved by NEU Engineer.

- If an alternate location for the ETS Room is necessary the Developer shall be responsible to pay the City the estimated increased piping costs determined by the NEU Engineer.
- The ETS Room shall be designated solely for the placement of NEU equipment. If the ETS Room must be located within the building's Mechanical Room, the ETS area must be kept clear of any other equipment.

Dimensions

- The ETS Room shall be rectangular and sized according to Table 2.
- Access to the ETS Room shall be designed so that an ETS skid of approximately 2 m x 3 m (6 ft. x 10 ft.) in size can be navigated through any hallways, doors, and/or turns leading to the ETS Room.

Access Door

- The ETS Room requires a minimum 1.83 m (6 ft.) wide standard height access double-door with zero clearance (no step) entry.
- If the door opens directly into the parkade area, ensure the door is protected from moving and parked vehicles.
- If the door swings into the ETS Room, the door swing area should not be counted as usable space within the ETS Room dimension.

Height

- The ETS Room requires typical headroom for a mechanical room, minimum 2.7 m (10 ft.), to accommodate the ETS skid.

Electrical

- The ETS Room shall be equipped with a single dedicated 120V, 15A circuit with lockable breaker for connection to the NEU Panel.

Floor Drain

- The ETS Room shall contain a floor drain. The floor drain should not be located in the centre of the room, but shall be within 200 mm of a wall.

Table 2: ETS Room Dimensions

| Building Net Floor Area | Minimum ETS Room Dimensions |
|---|------------------------------------|
| <150,000 ft ² (< 13,940 m ²) | 20 ft x 10 ft (6 m x 3 m) |
| Between 150,000 ft ² and 250,000 ft ² (Between 13,940 m ² and 23,230 m ²) | 20 ft x 13 ft (6 m x 4 m) |
| >250,000 ft ² (> 23,230 m ²) | To be determined by NEU Engineer |

6.2 NEU CONNECTIVITY REQUIREMENTS

The following requirements are verified prior to the release of the Building Permit.

6.2.1 Prohibited Equipment

The building mechanical system must not incorporate any heat production equipment as outlined in *the Energy Utility System By-Law No. 9552, Section 5.2*. The By-law also describes the exemptions that apply.

6.2.2 Base Building Design Strategies

The building shall be heated using a hydronic heating system compatible with the NEU at the temperatures specified in Table 1.

The building system shall be designed for a 35 kPa (5 PSI) pressure drop across the building side of the ETS heat exchangers.

Note the building side of the ETS heat exchangers are designed for a maximum pressure of 1,551 kPa (225 PSI). It is the responsibility of the Engineer of Record to ensure that building side heating and DHW systems meet local Code requirements for the pressure piping.

6.2.3 HVAC System Requirements

- Hot water generated by the ETS shall be distributed, via a 2-pipe (direct return) piping system, to the various heating elements throughout the building. The building heating system components shall be designed so that the resulting temperatures in the combined header connected to the ETS remain within the maximum allowed temperatures specified in Table 1 and follow the temperature reset curves in Figure 2.
- The specified differential temperature (ΔT) shall be regarded as a minimum requirement, and a larger ΔT is desirable to further reduce the pipe sizes and associated valves, fittings, etc., and pumping requirements in the secondary system. The building return temperatures must be kept to a minimum to allow the NEU's Energy Centre to operate efficiently.

The following information on building heating components should be regarded as guidelines only, and the Developer's Mechanical Engineer shall be responsible for the final (building-specific) design. If the building requires lower temperatures than as specified in the guidelines below, alternative design approaches can be used to obtain the minimum temperature differential (ΔT) requirement for efficient NEU service.

Hydronic Radiant Floor Heating

- Radiant floor heating shall be provided by PEX tubing installed within the floor structure just below the surface. The floor heating shall be designed for the following maximum temperatures:

| | |
|-----------------------|-----------|
| Radiant Floor Heating | HWS: 45°C |
| | HWR: 35°C |

Fin Type Baseboard Convectors/Perimeter Radiators

- The radiant (transmission) heating requirements shall be provided by 2-pass commercial fin type radiators or perimeter style radiant panels (European style) mounted on the perimeter of the outside walls. The baseboard convectors and perimeter wall mounted radiant panels shall be designed for the following maximum temperatures:

| | |
|-----------|-----------|
| Convector | HWS: 70°C |
| | HWR: 50°C |
| Radiators | HWS: 60°C |
| | HWR: 45°C |

Fan Coils

- Packaged fan coil units designed with hot water coils mounted on the inside walls can be used to provide individual unit heating. The fan coil units shall be designed for the following maximum temperatures:

| | |
|----------|-----------|
| Fan Coil | HWS: 70°C |
| | HWR: 50°C |

Hybrid Heat Pumps

- Hybrid heat pump units designed with hot water coils can be used if cooling is required. The major benefit of these units is that the compressor only runs when cooling is required and shuts down when in heating mode. This results in lower operating costs, reduced maintenance, reduced noise, extended unit life, and a more efficient system due to heat recovery options. The hybrid heat pumps shall be designed for the following maximum temperatures:

| | |
|------------------|-----------|
| Hybrid Heat Pump | HWS: 52°C |
| | HWR: 32°C |

Ventilation Make-Up Air Units

- The ventilation (make-up air) heating load shall be provided by air handling units designed with hot water/glycol heating coils. The coils shall be provided with freeze protection circuits. The heating coils shall be designed for the following maximum temperatures:

| | |
|-------------------------|-----------|
| Ventilation make Up Air | HWS: 65°C |
| | HWR: 45°C |

6.2.4 DHW System Requirements

The building systems shall be designed to meet all DHW requirements using energy supplied from the ETS.

The DHW system shall be designed in accordance with the design temperature specified below. The domestic hot water distribution systems are to be designed with re-circulation lines and pumps:

- City make-up domestic cold water: from 4.4 °C (winter) to 18 °C (summer)
- Domestic hot water: 60 °C

It is recommended that the DHW system be designed to provide only a moderate amount of storage, i.e. a 'semi-instantaneous' system, for buffering purposes. Cold water make-up should be introduced directly to the ETS, rather than to the storage tanks (see Figure 4). Storage tanks shall be located in close proximity to the ETS.

Note the building system is to include anti-scalding best practices to ensure water leaving the DHW storage tanks does not exceed the design temperature set point, as per the relevant Code requirements.

The building system shall be designed for a 35 kPa (5 PSI) pressure drop across the building side of the ETS heat exchangers. Note the building side of the ETS heat exchangers are designed for a maximum pressure of 1,551 kPa (225 PSI).

6.2.5 Electrical, Controls and Communications Requirements

The following shall be provided to facilitate communications from the building to the NEU.

- 1" dedicated conduit (with string) from the rooftop to the ETS Room.
- Dedicated 15A 110V circuit at rooftop to supply the antenna
- #6 gauge grounding wire at rooftop for the antenna
- Access to building prior to commissioning to facilitate the City installation of the antenna
- Internet connection via Ethernet with a dedicated Static IP and a unique port

Note that fibre optic connection may be suitable for some buildings; the NEU Engineer may request a fibre optic connection in lieu of the antenna provisions. This will be evaluated on a case-by-case basis.

The following shall be provided to the NEU Panel:

- An outdoor air temperature signal from the building
- Pump status via current sensors for each circulation pump that delivers flow to the ETS.

6.3 NEU SERVICE REQUIREMENTS

The following requirements are verified prior to commencement of NEU Service. The NEU Engineer will confirm the following requirements are met through the on-site commissioning and start-up meeting, to be coordinated by the Developer and involving all relevant trades.

- The building hydronic system shall be flushed prior to the commissioning of the ETS. Note that flushing through the heat exchangers is not permitted; the ETS must be bypassed with spool pieces during the flush. Provide written proof of flushing (flushing certificate and water quality test report) directly to NEU Engineer. Refer to By-law 9552 Schedule A for water quality specifications.
- The building's piping shall be tied into the skid-mounted ETS.
- Permanent electrical feed shall be installed and activated to the NEU Panel.
- Electrical provisions for accommodating a rooftop antenna shall be installed, including the grounding wire.
- Internet connection with Static IP to the NEU Panel
- Pump statuses from building pumps shall be tied into the NEU Panel.

6.4 ADDITIONAL GUIDANCE ON ENERGY MODELLING

For energy modelling of buildings connecting to the NEU, refer to the City of Vancouver's [Energy Modelling Guidelines](#).

For energy modelling of buildings connecting to the NEU and pursuing LEED certification, refer to the [Canada Green Building Council](#) for more guidance on how to account for the performance of the NEU to demonstrate energy performance improvements. The LEED energy model may require additional data about the NEU's inputs, efficiencies and various system parameters. Please contact neighbourhood.energy@vancouver.ca to obtain this data as needed.

7.0 SUBMITTAL CHECKLIST

7.1 DEVELOPMENT PERMIT

Provide the following documentation to support the Development Permit review. At this stage the NEU Engineer is checking for ETS Room Requirements (Section 6.1).

- Sealed architectural drawings in PDF format
- Architectural Plan View of the ETS Room and level in CAD format.

If an alternate location for the ETS Room has been agreed upon with the NEU Engineer, the Developer must provide a commitment letter to pay for the costs of the alternate location.

7.2 BUILDING PERMIT

Provide the following documentation to support the Building Permit review. At this stage the NEU Engineer is reaffirming ETS Room Requirements (Section 6.1) and checking for NEU Connectivity Requirement (Section 6.2).

To initiate the Connectivity Review process:

- Completed and signed Application for Thermal Energy Service
- Sealed building drawings shall include the following (to be submitted as a single ZIP file):
 - Full set of Mechanical drawings, including DHW, HVAC and controls schematics, Plumbing and Electrical equipment schedules and riser diagrams
 - Architectural drawings showing approved ETS Room location, NEU pipe penetration location, and NEU pipe routing.

To complete the Connectivity Review:

- Written response and acceptance of the Connectivity Review Memo
- Updated, signed and sealed Application for Thermal Energy Service
- CAD files for floor plan of ETS Room
- Pay Connection Levy and (if applicable) Alternate ETS Room Location fees
- Issued for Construction Drawings in PDF format.

7.3 COMMENCEMENT OF NEU SERVICE

Provide the following documentation prior to the commencement of NEU service. At this stage the NEU Engineer is checking for NEU Service Requirements (Section 6.3) prior to the on-site commissioning of the ETS.

- System flushing certificate
- Final HVAC Schematics for building heating and DHW systems, if any changes are made to the drawings set submitted at the end of Building Permit stage.
- As-built or record drawings in PDF format.

After correcting all deficiencies noted by the NEU Engineer as part of the ETS Commissioning process, provide the NEU Engineer with all necessary keys or access fobs to the ETS Room prior to commencement of NEU service.