



City of Vancouver *Planning - By-law Administration Bulletins*

Planning, Urban Design and Sustainability Department

453 W. 12th Ave Vancouver, BC V5Y 1V4 | tel: 3-1-1, outside Vancouver 604.873.7000 | fax: 604.873.7100

website: vancouver.ca | email: planning@vancouver.ca | app: VanConnect

NEIGHBOURHOOD ENERGY CONNECTIVITY STANDARDS - INFORMATION FOR DEVELOPERS

Authority - City Engineer

Effective August 2, 2011

Amended November 1, 2011, November 1, 2012 and December 11, 2013

***Disclaimer:** The following information is provided for general use and the user assumes all responsibility. The information contained within is general in nature and does not substitute for the execution of detailed engineering relative to specific projects or problems. The City nor any of their contractors or employees give any warranty expressed or implied, or assume any legal liability or responsibility for the accuracy, completeness, or usefulness of any information, product application, or process disclosed within this document. Nor are they liable for consequential damage whatever (including, without limitation, damages for loss of business profits, business interruption, loss of business information, or other losses) arising from the use of inability to use this document.*

1 Introduction and Intent

This document summarizes building design strategies required of developers in anticipation of future building connection to a Neighbourhood Energy System (NES). Developers are required to adopt these standards and make appropriate provisions in building mechanical design to enable them to take full advantage of the benefits offered through future NES connection.

Through adoption of these standards the need for future disruptive retrofits to buildings to make them NES-connectable is avoided, thereby reducing future costs of connection and inconvenience to occupants. Compliance with these standards will also act to improve overall building mechanical system efficiency.

2 What Buildings must be Connectable to a NES?

The City has identified high priority areas targeted for future Neighbourhood Energy service based on current density and/or anticipated growth potential. In these cases, the form of development must incorporate a NES-connectable interim approach to space heating and domestic hot water which will require minimal retrofits to connect to a NES in the future.

The requirement to design NES-connectable building heating systems is relevant in the following cases:

- (a) Where NES-connectable building design is specified as a development design requirement; and
- (b) Where the development proposes in **excess of 2,000 m² of heated floor space**.

Buildings smaller than 2,000 m² total heated floor space are generally, at this time, uneconomical to connect to a NES, therefore connectivity design provisions are not required in these cases.

In such instances where both these conditions apply, these connectivity standards provided in Section 4 below must be incorporated for future building compatibility with a NES.

3 Background

3.1 Sustainable Energy Strategy

The City of Vancouver's Sustainable Energy Strategy is focused on identifying and implementing actions that reduce greenhouse gas (GHG) emissions associated with energy usage for building space, ventilation, and hot water heating. The strategy focuses on neighbourhood energy as a means to significantly reduce GHG emissions over a business-as-usual approach to building heating design. Neighbourhood energy accomplishes these GHG reductions through the flexibility to adapt to a wide variety of renewable energy sources that would otherwise be unavailable to an individual building development.

The City's NES strategy involves two key actions:

- (a) Connection of new buildings to systems where existing NES are established or under development (e.g. Southeast False Creek, East Fraserlands and Northeast False Creek), and
- (b) Ensure that buildings are constructed with NES-compatible hydronic heating systems in medium to high density areas that do not currently have a NES, but are likely to in the future.

These standards are provided to assist developers in meeting the design requirements of a NES-compatible heating system in areas where a NES does not currently exist, but is likely to in the future.

3.2 What is Neighbourhood Energy?

Neighbourhood energy systems are commonplace in many parts of the world, and provide heat energy services (for space heat and domestic hot water) and/or cooling energy services. These systems are commonplace in northern European countries and provide the following benefits:

- (a) **Environmental Benefits:** NES provide economies of scale and flexible infrastructure that can adapt to using a wide variety of renewable and waste energy options that would otherwise not be available to an individual building heating system. The heating of buildings generates half of our City's greenhouse gas emissions, and the use of renewables-based NES results in substantial emission reductions.
- (b) **Social Benefits:** Through NES's use of local and renewable energy sources and flexibility to adapt to future energy technologies, it is anticipated that NES customers typically enjoy rate stability that outperforms conventional options. Also, NES support the use of radiant hot water heating systems in buildings which provide customers with a higher level of comfort at a lower energy use, as compared to conventional space heating options.
- (c) **Economic Benefits:** NES's are typically self-funded utilities that provide substantial GHG reductions without additional cost to society. In addition, NES's can help building owners meet the energy efficiency and green building targets more cost effectively as compared to the use of distributed stand-alone green energy options, such as geoexchange.

A NES consists of the following key components:

- (1) **Community Energy Centre:** A centralized energy plant employing one or more of various technologies to produce hot water. Energy sources may change over time in response to changes fuel prices and technologies. The long-term objective is for most of the energy production to be sourced from renewable technologies. Natural gas boilers may be used for back-up and peaking energy, and also as an interim heat source until there is adequate energy demand to provide revenues to cover the cost of a renewable technology.
- (2) **Thermal Distribution System:** Consisting of a two pipe system providing separate supply and return loop hot water, buried in the streets between the Community Energy Centre and the building Energy Transfer Stations.
- (3) **Energy Transfer Stations (ETS):** Each NES customer building has an ETS as the interface between the NES and the in-building thermal distribution system. The ETS includes equipment installed and operated by the neighbourhood energy provider including the necessary pipes, heat exchangers and associated controls and energy meters. This equipment is typically located inside the customer building mechanical room.

Figure 1. Typical ETS Installation in Building Basement

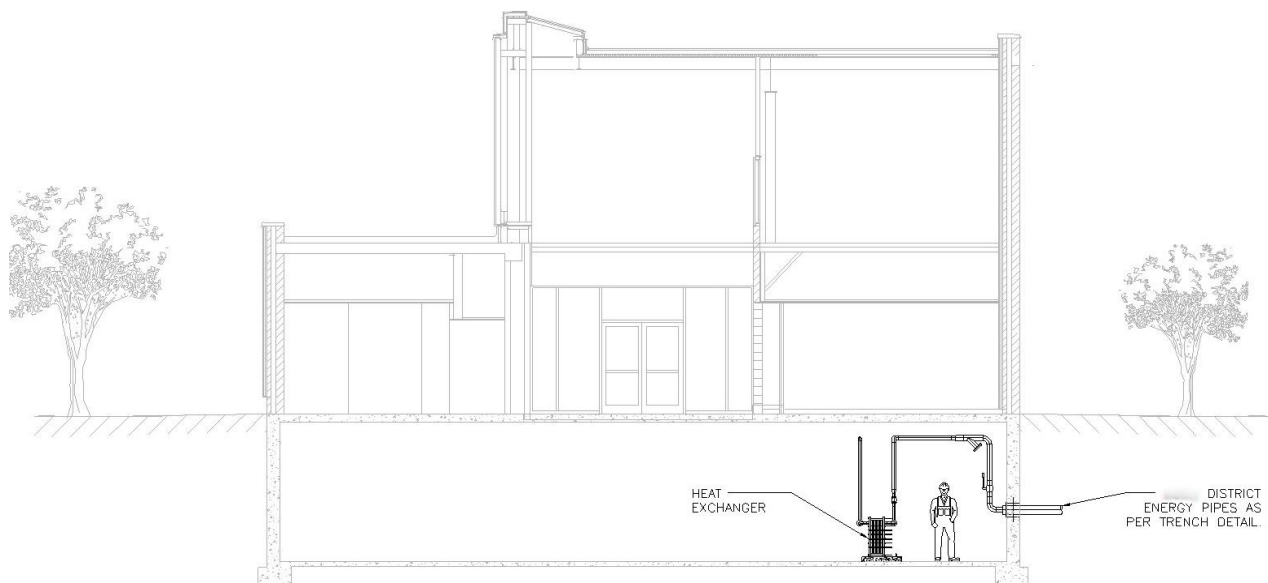

As shown in Figure 2 below, the primary flow through the ETS is controlled to achieve the design supply temperature to the building on the secondary side, i.e. on the building internal hydronic system.

Figure 2. In Building ETS Flow Schematic

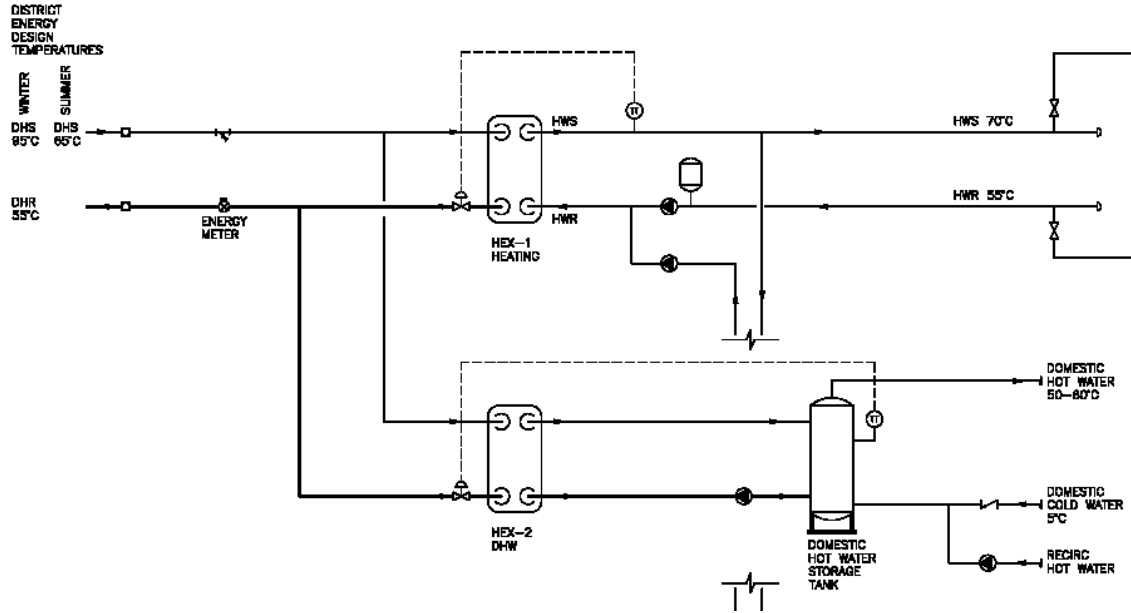
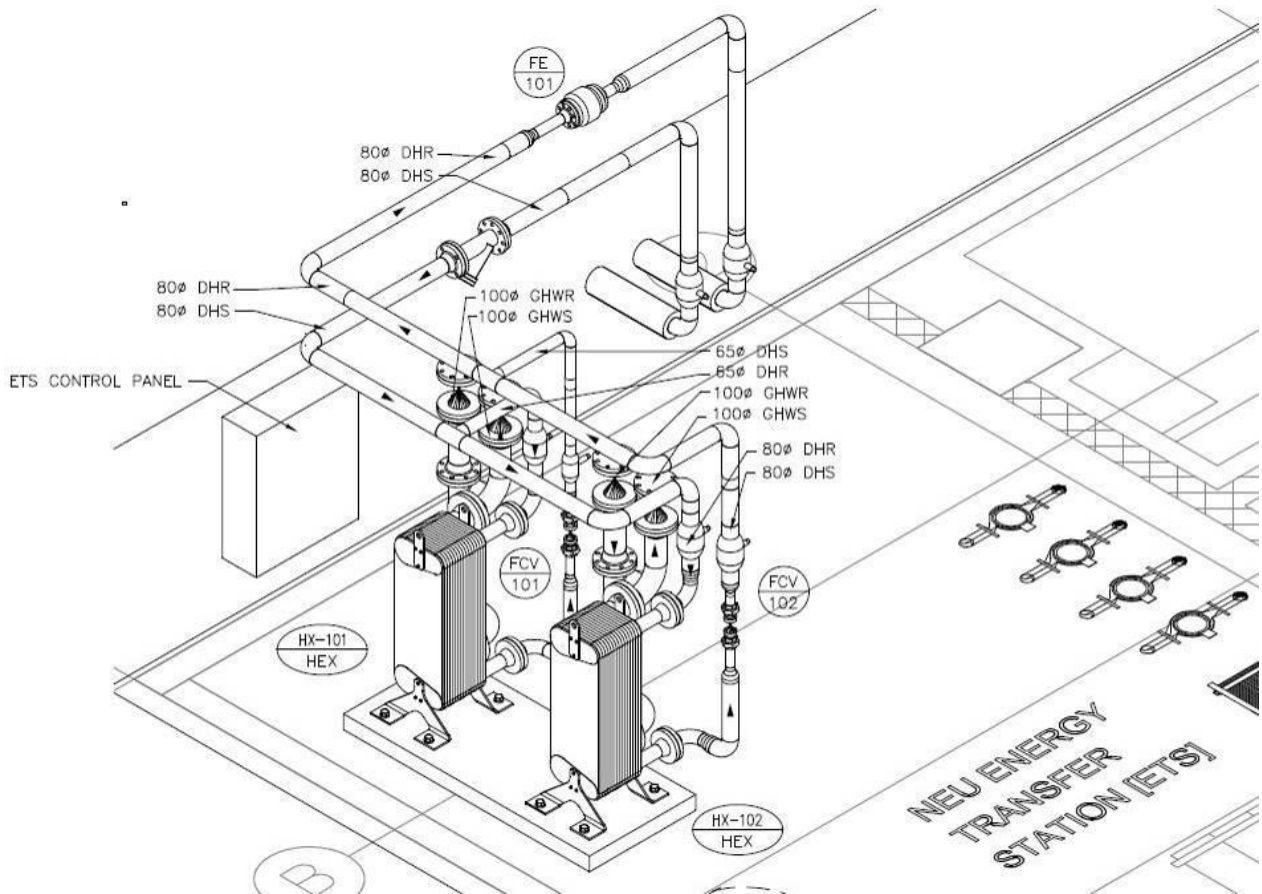

Figure 3. Typical ETS (Detail)



4 Requirements for NES-Connectable Hydronic Systems in Buildings

4.1 Overview

For future NES-connectivity, hydronic (hot water) heating systems are required with heating equipment centralized in a common mechanical room located such that connection to the future NES piping system is feasible. The preferred location for the building mechanical room is in the basement, parkade, or ground level. Once a NES is developed, the building mechanical room will become home to the ETS (i.e. the building interface with the NES piping).

The remaining sections provide technical information for NES-compatible hydronic space heating and domestic hot water systems for new construction and/or building retrofits. The design information provided in this specification should be regarded as a general guideline only, and the developer's Mechanical Engineer shall be responsible for the final building heating system design. If the building requires lower temperatures than as specified in the standards below, alternative design approaches can be used to obtain the minimum differential temperature (ΔT) requirement for efficient future NES service.

4.2 Pumping and Control Strategy

The building heating system shall be designed for variable volume flow operation (preferably with variable speed pumps to minimize the pumping power requirements and to achieve the minimum water temperature drop). All control valves (terminal units and zone valves) are to be of 2-way modulating (or on/off for Fan Coil Units) type. The system must not include 3-way valves that allow flow to by-pass the heating elements.

Figure 4. Temperature Reset Curve for Vancouver

(Fan Coil Units and Radiant Floor/Panel Heating - Option 1 and 3, No Reheat included)

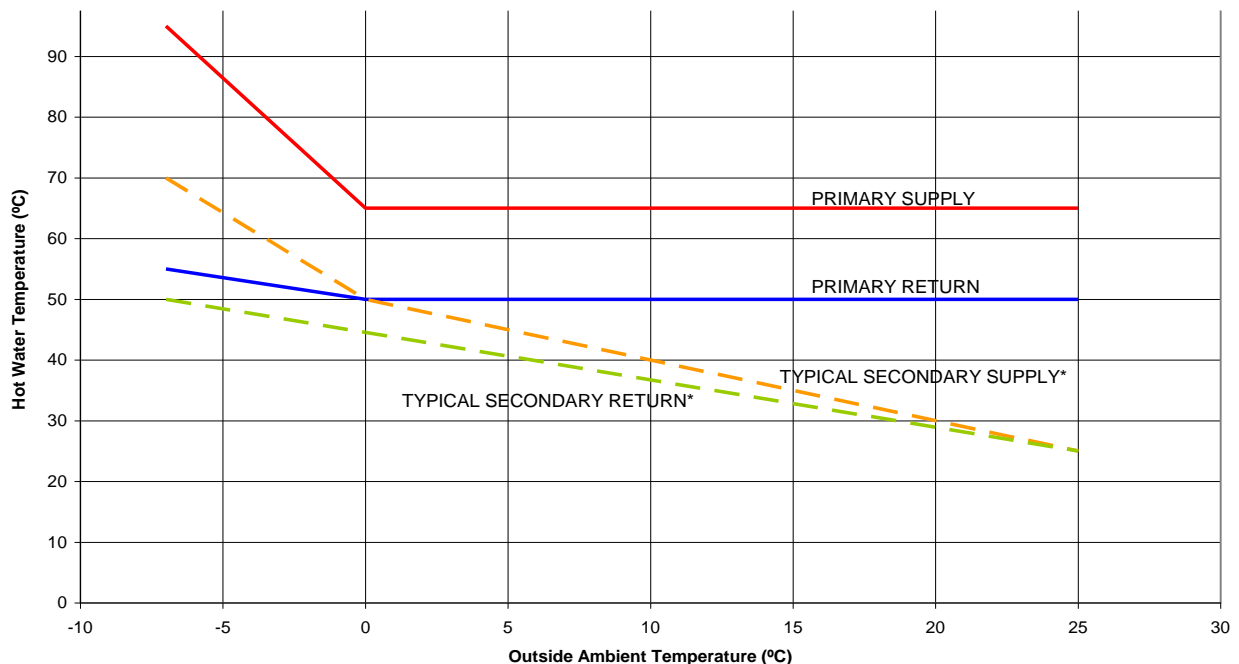

Notes:

* Space heating only, direct primary domestic hot water heating with maximum 60°C domestic hot water supply
Primary supply / return = Neighbourhood heating system supply / return
Secondary supply / return = Building mechanical system supply / return

The building (secondary) supply temperature shall be reset based on outside air temperature according to the guidelines provided in Figure 4 above. The temperature reset strategy should be implemented to allow the control valves to operate within the middle portion of their operating ranges. This tends to prevent laminar flow conditions (by maintaining tube velocities above minimum) and thus maintaining a high heat transfer coefficient through the heating coils and other terminal devices, producing low return temperatures at all load conditions.

From the NES system perspective, a successful operation of the hot water neighbourhood heating system depends greatly on the ability of the designers and operators to obtain high temperature differentials (ΔT) between the supply and return water. This is critical to minimize the heat and pumping losses and maximize the (heat pump) plant efficiency to ensure that the NES system can provide the design capacities at optimum efficiencies year round. The single most important factor to achieve the design temperatures at the plant and in the distribution system is the ability of the buildings connected to the system to provide the **lowest possible return temperatures** on a consistent basis.

4.3 Hydronic Heating and Domestic Hot Water Systems (Minimum) Requirements

The hot water hydronic heating system shall be designed to provide all of the space heating and ventilation air heating requirements for the individual suites, hallways/stairwells and other common areas in the building, supplied from a central mechanical room within the building. Hot water shall be distributed, via a 2-pipe (direct return) piping system, to the various heating elements throughout the building.

The specified ΔT shall be regarded as a minimum requirement, and **a larger ΔT is desirable** to further reduce the pipe sizes and associated valves, fittings, etc., pumping requirements and energy losses in the secondary system. The building return temperatures must be kept to a minimum to allow the future NES energy plant to take advantage of alternate energy efficient technologies.

The building heating system must be designed to operate in a temperate regime that will be compatible with the future neighbourhood energy service, which is comparable to a condensing natural gas boiler. Hydronic heating can be delivered in a variety of forms including radiant floor/ceiling systems, hot water base-boards, fan coils, etc. Owners and developers can receive support and guidance from the City of Vancouver in designing their HVAC systems to derive the most benefit from a future NES connection. The building (secondary) heating system shall be designed according to the design temperatures specified below for several common types of systems.

Hydronic Radiant Floor Heating

Floor heating shall be designed for the following maximum temperatures:

Hot water supply:	45°C
Hot water return:	35°C

Fin Type Baseboard Convectors / Perimeter Radiators

The radiant heating shall be provided by 2-pass commercial fin type radiators or perimeter style radiant panels (European style). The baseboard convectors and radiant panels shall be designed for the following maximum temperatures:

Convectors:	Hot water supply:	70°C
	Hot water return:	50°C
Radiators:	Hot water supply:	60°C
	Hot water return:	45°C

Fan Coils

Packaged fan coil units designed with hot water coils mounted on the inside walls can be used to provide individual unit heating. The fan coil units shall be designed for a minimum of a two row coil and the following maximum temperatures:

Hot water supply:	70°C
Hot water return:	50°C

Ventilation Make-Up Air Units

The ventilation (make-up air) requirements shall be provided by air handling units designed with hot water/glycol heating coils. The heating coils shall be designed for the following maximum temperatures:

Hot water supply:	65°C
Hot water return:	45°C

Domestic Hot Water

The domestic hot water system is to be designed in accordance with the design temperature specified below. The domestic hot water distribution systems are to be designed with re-circulation lines and pumps.

Domestic cold water:	5°C
Domestic hot water:	60°C

5 Letters of Assurance

Confirmation by the registered professional of record that the design of the building HVAC system complies with these design requirements must be provided prior to issuance of a building permit.

6 Contact Information

For additional information contact Kieran McConnell at Kieran.McConnell@vancouver.ca or 604.871.6981.

