

Bulletin

Parking By-Law No. 6059 Design Supplement

Effective July 12, 1988

Last amended February 16, 2024

Authority: Director of Planning and City Engineer

Table of Contents

- 1. Ramp Design.....4
 - 1.1 Access.....4
 - 1.2 Grades4
 - 1.3 Widths4
 - 1.4 Sightline Obstructions4
 - 1.4.1 Corner Cuts4
 - 1.4.2 Mirrors5
 - 1.5 Security Door Controls.....5
- 2. Parking Space Design5
 - 2.1 Parking Space Size.....5
 - 2.2 Accessible Spaces5
 - 2.3 Maneuvering Aisle Width5
 - 2.4 Walls, Columns, and Side Clearance Widths8
 - 2.5 Projections Over a Space10
 - 2.6 Ticket Dispensers.....10
 - 2.7 Motorcycles.....10
 - 2.8 Additional Design Considerations11
- 3. Loading Space Design11
 - 3.1 Loading Space Sizes11
 - 3.1.1 Loading and Unloading.....11
 - 3.2 Maneuvering Aisle Width11
 - 3.2.1 Reduced Maneuvering Aisle Widths12
 - 3.3 Walls, Columns, and Side Clearance Widths12
 - 3.3.1 Class A Loading.....13
 - 3.3.2 Class B Loading13
 - 3.3.3 Class C Loading.....13
 - 3.4 Additional design considerations13
- 4. Bicycle Space Design14
- 5. Passenger Space Design.....14
 - 5.1 Passenger Loading Space Sizes14
 - 5.2 Maneuvering Aisle Width14
 - 5.2.1 Class A Passenger Loading14
 - 5.2.2 Class B Passenger Loading14
 - 5.2.3 Class C Passenger Loading14

5.2.4	Reduced Maneuvering Aisle Widths	14
5.3	Walls, Columns, and Side Clearance Widths	15
5.3.1	Class A Passenger Loading	15
5.3.2	Class B Passenger Loading	15
5.3.3	Class C Passenger Loading	15
5.4	Additional design considerations	15

List of Tables

Table 1: Minimum Ramp Widths.....	4
Table 2: Minimum Maneuvering Aisle Widths.....	8
Table 3: Loading Design Vehicles	12
Table 2: Passenger Loading Design Vehicles.....	16

List of Figures

Figure 1: Parking Space Minimum Widths (all dimensions in metres).....	6
Figure 2: Accessible Space Dimensions (all dimensions in metres)	7
Figure 3: Walls, Columns, and Side Clearance Widths (all dimensions in metres).....	9
Figure 4: Projections Over a Space (all dimensions in metres).....	10
Figure 5: Loading Space Design (all dimensions in metres)	13
Figure 6: Passenger Loading Space Design (all dimensions in metres).....	17

As part of the rezoning and development permit application processes, staff review development drawings to ensure that parking, loading, bicycle, and passenger loading space designs meet City by-laws and guidelines for safe, functional access. The following design criteria, supplementary to the Parking By-law 6059, should be satisfied. In conjunction with this bulletin, good engineering practices are to be followed in all circumstances to ensure public safety.

1. Ramp Design

1.1 Access

Access to a development site generally should be provided from the lane, or the lowest classified roadway where there is no lane available, and be limited to one (1) access point. Access is not permitted from bikeways or greenways.

1.2 Grades

The maximum ramp slope allowed in the first 6.1 m from the property line is 10%.

The maximum slope after the first 6.1 m from the property line is 12.5%. On extreme hardship sites, slopes up to 15% may be acceptable if a 7.5% to 10% transition ramp or continuous transition curve is provided at the bottom for at least 4 m in length. Ramps which have a 15% slope and are exposed to the weather should be heated.

The maximum slope permitted for ramps intended to service Class B or Class C loading is 10%.

The percent of slope, the length of the ramp at the specified slope, and design elevations on both sides of the ramp at all break points (plus along the centre of travel lanes in curves) should be shown on the submitted drawings.

1.3 Widths

The minimum required width of parking ramps are provided in **Table 1**.

Table 1: Minimum Ramp Widths

To/From	Number of Parking Spaces	Minimum Width
A Residential Street or Lane	19 or fewer	3.6 m
A Residential Street or Lane	20 or more	6.1 m
A Collector or an Arterial Street	9 or fewer	3.6 m
A Collector or an Arterial Street	10 or more	6.1 m

1.4 Sightline Obstructions

1.4.1 Corner Cuts

Where views to pedestrians would otherwise be obstructed, diagonal corner cuts or view portals are required. View portals at the top or bottom of ramps within underground parking areas may also be required to provide improved visibility of oncoming vehicles.

Corner cuts are required at the top and bottom of ramps to provide adequate radii for continuous two-way traffic flow where 200 or more vehicles are being served. A standard 6 m ramp width would require a 2.7 m x 2.7 m corner cut. Reduced corner cuts may be acceptable for wider ramps upon staff review.

1.4.2 Mirrors

Convex mirrors are required at those locations, such as 90-degree jogs in access ramps, where opposing motorists cannot readily view each other.

1.5 Security Door Controls

If a key lock, or similar security system, is to be used on a driveway designed for two-way movement, the activation unit should be placed in the middle of the ramp, and the ramp should be at least 6.7 m wide. Where a driveway with two-way movement is of lesser width, the overhead security door should be activated by a remote-control unit in the vehicle. This should be noted on submitted drawings. Where the driveway is accessed from a street, as opposed to a lane, the security door (and activation unit, if applicable) should be positioned such that a vehicle is fully on private property when stopped to activate the door.

2. Parking Space Design

2.1 Parking Space Size

Required dimensions for standard spaces, small car spaces, standard accessible spaces, and van accessible spaces are prescribed in [Section 4 of the Parking By-law](#).

The depth and width of standard and small car spaces may be reduced for angled parking spaces, as shown in **Figure 1**.

2.2 Accessible Spaces

If standard accessible spaces are located beside one another or beside a walkway or open area, then the following minimum standards, and as shown in **Figure 2** should be satisfied.

Accessible spaces may be 2.5 m wide with a wheelchair accessible 1.5 m wide access corridor. Van accessible spaces with a shared access aisle should be a minimum of 5.5 m in length and 3.5 m in width, have a minimum vertical clearance of 2.3 m, along with a shared access aisle of 1.5 m in width.

2.3 Maneuvering Aisle Width

Maneuvering aisles are, in effect, a hammerhead access to and from parking spaces. Where the parking space is aligned at a 90-degree angle to the wall, a 6.6 m wide maneuvering aisle is required. The maneuvering aisle width may be reduced for small car spaces, or if the angle of parking is less than 90 degrees, as shown in **Table 2**.

Figure 1: Parking Space Minimum Widths (all dimensions in metres)

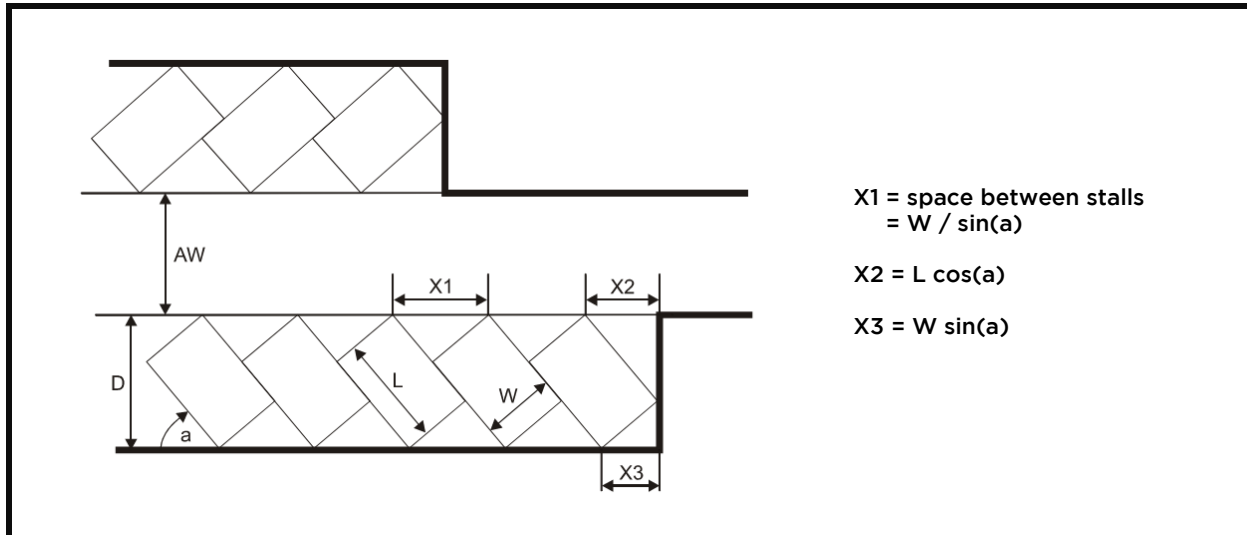

$X1 = \text{space between stalls} = W / \sin(a)$
 $X2 = L \cos(a)$
 $X3 = W \sin(a)$

Parking Angle (a)	Depth of Stall (D)				Aisle Width (AW)
	Standard Spaces (W =)		Small Car Spaces (W =)		
	2.50	2.70*	2.30	2.60*	
0 degrees (parallel)	All parallel spaces shall be 2.5m x 6.4m				3.6
20 degrees	4.23	4.42	3.73	4.02	3.6
25 degrees	4.59	4.77	4.03	4.30	3.6
30 degrees	4.92	5.09	4.29	4.55	3.6
35 degrees	5.20	5.37	4.52	4.77	3.6
40 degrees	5.45	5.60	4.72	4.95	3.6
45 degrees	5.66	5.80	4.88	5.09	3.9
50 degrees	5.82	5.95	5.00	5.20	4.2
55 degrees	5.94	6.05	5.09	5.26	4.5
60 degrees	6.01	6.11	5.13	5.28	4.8
65 degrees	6.04	6.13	5.14	5.27	5.1
70 degrees	6.02	6.09	5.11	5.21	5.4
75 degrees	5.96	6.01	5.04	5.12	5.3
80 degrees	5.85	5.89	4.93	4.98	5.8
85 degrees	5.70	5.71	4.78	4.81	6.2
90 degrees	5.50	5.50	4.60	4.60	6.6

*If a parking stall is adjacent to a wall, or if a column is located more than 1.2 m from either end of the stall, then the required stall width is 2.7 m for a standard vehicle, and 2.6 m for a small car.

Figure 2: Accessible Space Dimensions (all dimensions in metres)

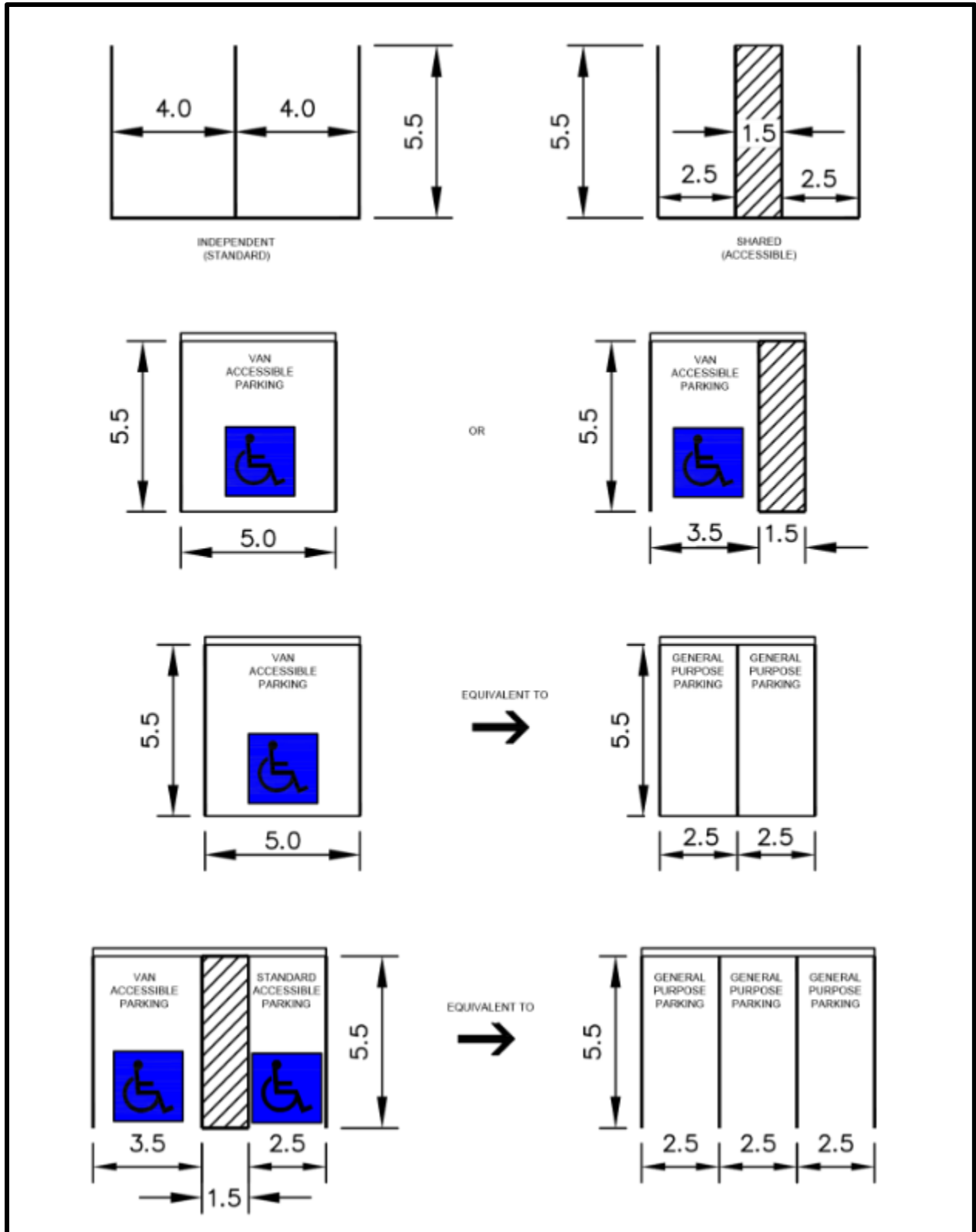

Table 2: Minimum Maneuvering Aisle Widths

Values for Decreasing Aisle Widths		Examples of Various Minimum Aisle Widths Applied to Factors					
Stall Width	Factor	90 degrees 6.6 m**	80 degrees 5.8 m**	70 degrees 5.1 m**	60 degrees 4.5 m**	50 degrees 3.9 m**	45 degrees (or less) 3.6 m**
2.30 - 2.54*	1.000	6.60	5.80	5.10	4.50	3.90	3.60
2.55 - 2.59	0.985	6.50	5.71	5.02	4.43	3.84	3.55
2.60 - 2.64	0.970	6.40	5.63	4.95	4.37	3.78	3.49
2.65 - 2.69	0.955	6.30	5.54	4.87	4.30	3.72	3.44
2.70 - 2.74	0.939	6.20	5.45	4.79	4.23	3.66	3.38
2.75 +	0.924	6.10	5.34	4.71	4.16	3.60	3.35

* up to 2.54 m is considered to be no increase above minimum stall width.
 ** minimum aisle width for minimum stall width (2.54m or less)

2.4 Walls, Columns, and Side Clearance Widths

If a parking stall is adjacent to a wall, or if a column is located more than 1.2 m from either end of the stall, then the required stall width is 2.7 m for a standard vehicle, and 2.6 m for a small car.

If column encroachments are proposed, the following minimum standards, and as shown in **Figure 3**, should be satisfied:

- a) A 3-vehicle span for general purpose parking requires a minimum width of 7.5 m with a maximum of 0.15 m column encroachment. The three-vehicle span design accommodates one (1) van-accessible space for one (1) accessible space with a shared access aisle. Note: this restricts columns to a maximum 0.3 m width centred on the space dividing line.
- b) Any column encroachment on a 2.5 m wide parking space should be set back from the maneuvering aisle yet respect the 1.2 m maximum limit from the end of the space. For example, if the column depth is 0.6 m long, then it should be set back 0.6 m from a standard 6.6 m maneuvering aisle. However, if a proposed maneuvering aisle exceeds the 6.6 m minimum, the column need not be set back as far. For example, the minimum required column setback from a 6.9 m maneuvering aisle is 0.3 m and from a 7.2 m maneuvering aisle is nil. Should a column 0.9 m long be required, then it should be set back 0.3 m, but a standard width maneuvering aisle is acceptable.
- c) No column encroachments will be accepted for single space modules having columns on both sides of the space. Furthermore, although there are no column encroachments, submissions as per this example will still require columns to be set back as per (b).
- d) Column encroachments up to 0.15 m on small car spaces are also acceptable provided the required setbacks as noted in (b) above are met.
- e) Columns are not permitted within the access aisles of accessible spaces.

Figure 3: Walls, Columns, and Side Clearance Widths (all dimensions in metres)

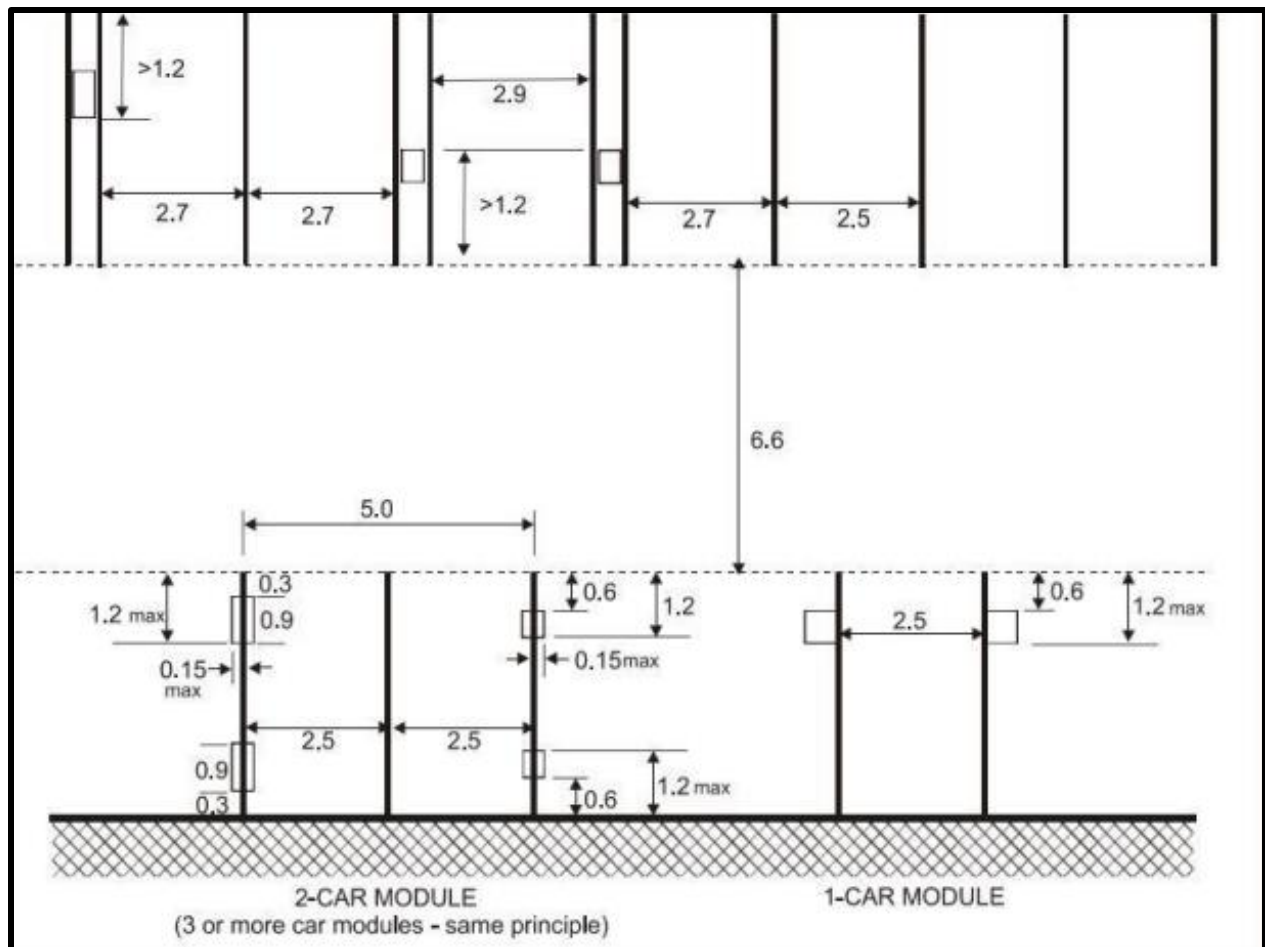

2.5 Projections Over a Space

Projections over a space normally occur with shallow sites which require an overlapping split-level design for the parking structure. If projections are unavoidable due to site constraints, vertical clearance should not be less than 1.2 m and projection into the space from the wall should not be more than 1.2 m. The corner of such projection is to be chamfered at 45 degrees for a minimum of 10 cm and the vertical face of at least every other space marked "CAUTION - LOW CLEARANCE" in minimum 10 cm high black letters on a yellow background. Permitted projections over a space are illustrated in Figure 4.

Figure 4: Projections Over a Space (all dimensions in metres)

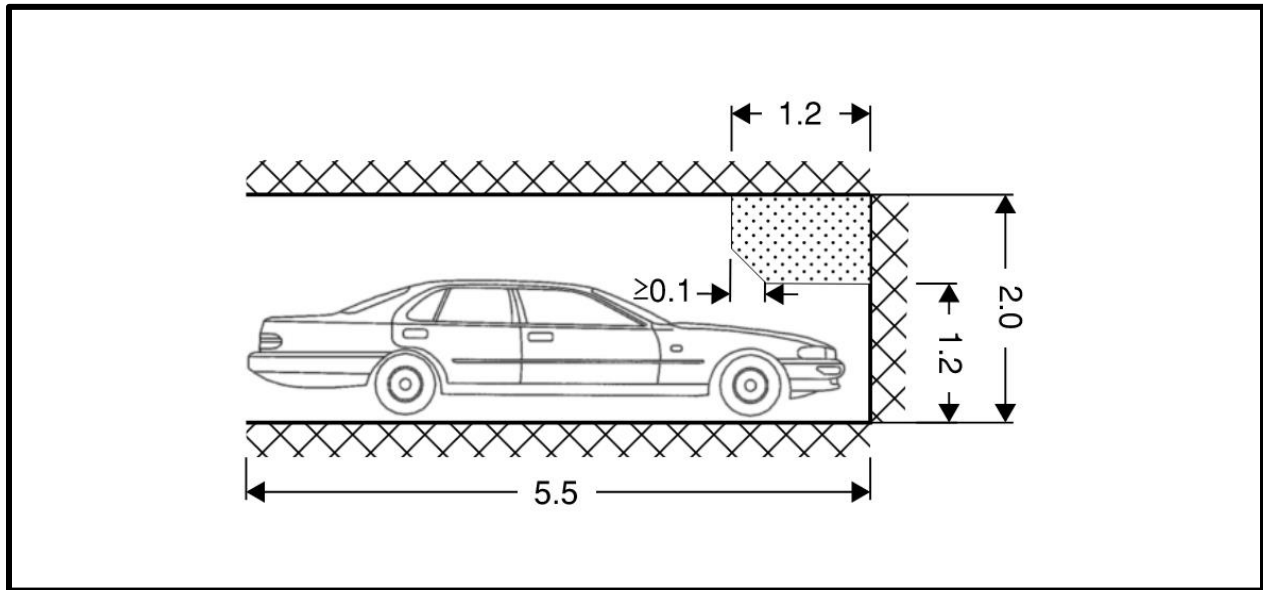

2.6 Ticket Dispensers

Ticket dispensers with automatic gates normally should be located not less than 15 m inside the property line measured along the driveway centreline. At entrances where an attendant controls entry and exit, the booth normally should be located not less than 30 m from the property line measured along the driveway centreline. If the attendant only controls the exit lane, then the 15 m distance will apply.

2.7 Motorcycles

A space designated for the parking of a motorcycle should be a minimum of 1.5 m wide and 2.4 m long and clearly marked "Motorcycle Parking".

Motorcycle spaces do not count toward minimum vehicle parking spaces required under the Parking By-law. There is no minimum requirement for motorcycle spaces.

2.8 Additional Design Considerations

Each parking space should be numbered on the drawings so that it may be uniquely identified by reviewing staff.

Design of on-site circulation should be logical and efficient. The following items should be considered for on-site circulation and layout:

- a) Right hand drive should be maintained to, from and throughout the site.
- b) Circuitous routings to obscure parking or loading areas should be avoided.
- c) Parking should be laid out such that it does not require a vehicle to back up for more than 10 m.
- d) Parking layouts should be such that vehicles exit the parking area in a forward direction, except where the lane serves as the maneuvering aisle or in RS and RT zoning.
- e) In those cases where a parking space requires that a vehicle make a 180 degree turn, adequate area should be provided so this may be accomplished without undue difficulty.
- f) Interior access, circulation, and maneuvering areas should provide minimum vertical clearances, per the Parking By-law, for the type of space they are intended to serve.
- g) The location of visitor parking should be convenient to the ground level.
- h) The maximum slope and crossfall permitted in a parking space or access aisle is 5%.

3. Loading Space Design

3.1 Loading Space Sizes

Required dimensions for loading spaces are prescribed in [Section 5 of the Parking By-law](#).

3.1.1 Loading and Unloading

Provision of a clear unloading area or raised rear dock, minimum 1.8 m wide, with suitable access to facilitate goods loading and unloading is required. Alternatively, an overhead door, or an access corridor leading to an entry door may be provided. For smaller developments on narrow lots, an entry door at the end of a loading space is normally sufficient.

3.2 Maneuvering Aisle Width

Required maneuvering aisle widths for loading spaces are prescribed in [Section 5 of the Parking By-law](#).

3.2.1 Reduced Maneuvering Aisle Widths

Loading spaces that are at an angle less than 90 degrees to the maneuvering aisle should be dimensioned as determined by the Director of Planning, in consultation with the City Engineer. For staff review, drawings should be submitted illustrating satisfactory access and egress to angled passenger loading spaces using the design vehicles as illustrated in **Table 3**.

Table 3: Loading Design Vehicles

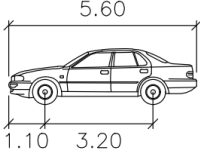
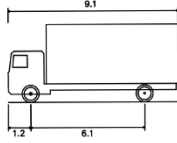
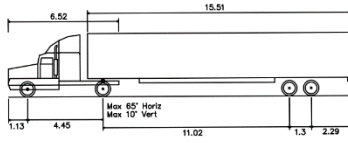
Space Classification	Design Vehicle																	
Class A Loading	Passenger (P)	 <p>P</p> <table border="0"> <tr> <td></td> <td style="text-align: right;">meters</td> </tr> <tr> <td>Width</td> <td style="text-align: right;">: 2.00</td> </tr> <tr> <td>Track</td> <td style="text-align: right;">: 2.00</td> </tr> <tr> <td>Lock to Lock Time</td> <td style="text-align: right;">: 6.0</td> </tr> <tr> <td>Steering Angle</td> <td style="text-align: right;">: 35.9</td> </tr> </table>		meters	Width	: 2.00	Track	: 2.00	Lock to Lock Time	: 6.0	Steering Angle	: 35.9						
	meters																	
Width	: 2.00																	
Track	: 2.00																	
Lock to Lock Time	: 6.0																	
Steering Angle	: 35.9																	
Class B Loading	SU-9	 <table border="0"> <tr> <td>SU9 – Single Unit or Bus</td> <td></td> </tr> <tr> <td>Overall Length</td> <td style="text-align: right;">9.100m</td> </tr> <tr> <td>Overall Width</td> <td style="text-align: right;">2.600m</td> </tr> <tr> <td>Overall Body Height</td> <td style="text-align: right;">4.150m</td> </tr> <tr> <td>Min Body Ground Clearance</td> <td style="text-align: right;">0.445m</td> </tr> <tr> <td>Track Width</td> <td style="text-align: right;">2.600m</td> </tr> <tr> <td>Lock-to-lock time</td> <td style="text-align: right;">4.00s</td> </tr> <tr> <td>Curb to Curb Turning Radius</td> <td style="text-align: right;">12.800m</td> </tr> </table>	SU9 – Single Unit or Bus		Overall Length	9.100m	Overall Width	2.600m	Overall Body Height	4.150m	Min Body Ground Clearance	0.445m	Track Width	2.600m	Lock-to-lock time	4.00s	Curb to Curb Turning Radius	12.800m
SU9 – Single Unit or Bus																		
Overall Length	9.100m																	
Overall Width	2.600m																	
Overall Body Height	4.150m																	
Min Body Ground Clearance	0.445m																	
Track Width	2.600m																	
Lock-to-lock time	4.00s																	
Curb to Curb Turning Radius	12.800m																	
Class C Loading	WB-17	 <table border="0"> <tr> <td>WB-17 – Large Semi-Trailer</td> <td></td> </tr> <tr> <td>Overall Length</td> <td style="text-align: right;">20.190m</td> </tr> <tr> <td>Overall Width</td> <td style="text-align: right;">2.600m</td> </tr> <tr> <td>Overall Body Height</td> <td style="text-align: right;">3.730m</td> </tr> <tr> <td>Min Body Ground Clearance</td> <td style="text-align: right;">0.435m</td> </tr> <tr> <td>Track Width</td> <td style="text-align: right;">2.600m</td> </tr> <tr> <td>Lock-to-lock time</td> <td style="text-align: right;">6.00s</td> </tr> <tr> <td>Curb to Curb Turning Radius</td> <td style="text-align: right;">13.700m</td> </tr> </table>	WB-17 – Large Semi-Trailer		Overall Length	20.190m	Overall Width	2.600m	Overall Body Height	3.730m	Min Body Ground Clearance	0.435m	Track Width	2.600m	Lock-to-lock time	6.00s	Curb to Curb Turning Radius	13.700m
WB-17 – Large Semi-Trailer																		
Overall Length	20.190m																	
Overall Width	2.600m																	
Overall Body Height	3.730m																	
Min Body Ground Clearance	0.435m																	
Track Width	2.600m																	
Lock-to-lock time	6.00s																	
Curb to Curb Turning Radius	13.700m																	

3.3 Walls, Columns, and Side Clearance Widths

The following minimum column setbacks and side clearances, and as shown in **Figure 5**, should be satisfied for columns directly adjacent to loading spaces:

3.3.1 Class A Loading

For Class A loading spaces, column encroachments are permitted per **Section 2.4 Walls, Columns, and Side Clearance Widths for Parking Spaces**. No additional side clearance width is required.

3.3.2 Class B Loading

For Class B loading spaces, columns should be placed at least 3.3 m away from the maneuvering aisle. Column encroachments are not permitted into the loading spaces.

Each Class B loading space requires a minimum side clearance of 1.3 m, which may be provided on either side of the space. Except that two side-by-side Class B loading spaces may share the same 1.3 m clearance width.

3.3.3 Class C Loading

For Class C loading spaces, columns should be placed at least 8.6 m from the maneuvering aisle. Column encroachments are not permitted into the loading spaces.

Each Class C loading space requires a minimum side clearance of 3.1 m, which may be provided on either side of the space. Except that two side-by-side Class C loading spaces may share the same 3.1 m clearance width.

3.4 Additional design considerations

- Where required by the Parking By-law or applicable area plan, at least one (1) Class A loading space should be accommodated at-grade, accessed from the lane of all new developments.
- The maximum slope and crossfall permitted in a loading space or access aisle is 5%.
- Convenient, internal, stair-free access to and from all land uses should be provided on mixed-use sites for all loading spaces provided.

Figure 5: Loading Space Design (all dimensions in metres)

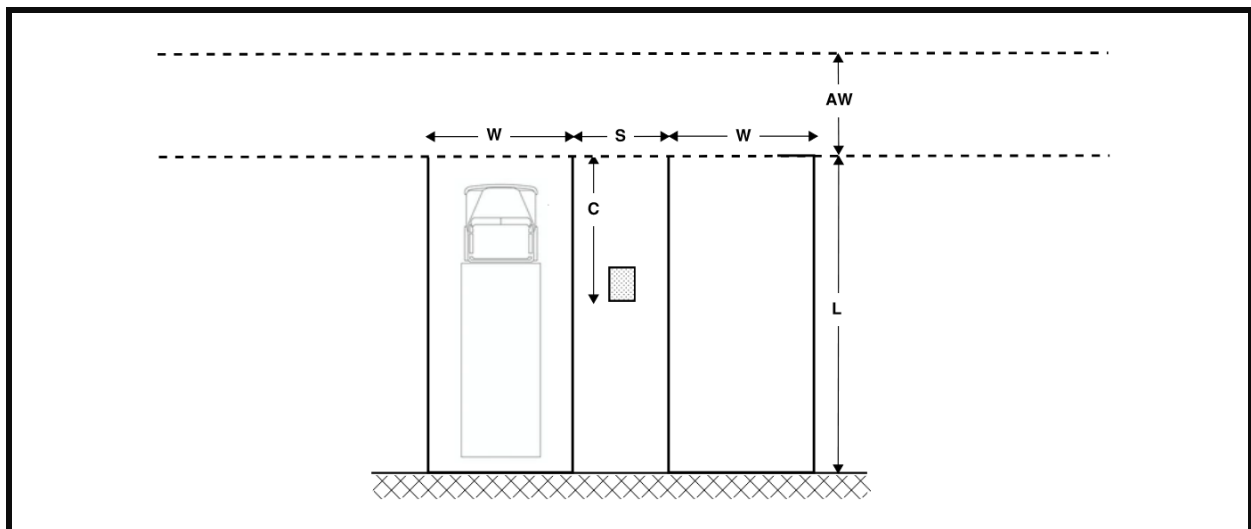

Loading Space Classification	Aisle Width (AW)	Column Setback (C)	Side Clearance (S)	Width (W)	Length (L)
Class A	6.1	Section 2.4: Walls, Columns, and Side Clearance Widths for Parking Spaces	0.0	2.7	5.5
Class B	6.1	3.3	1.3	3.4	10.2
Class C	14.0	8.6	3.1	3.6	23.1

4. Bicycle Space Design

Required dimensions and design specification for bicycle spaces are prescribed in [Section 6 of the Parking By-law](#).

5. Passenger Space Design

5.1 Passenger Loading Space Sizes

Required dimensions for passenger loading spaces are prescribed in [Section 7 of the Parking By-law](#).

5.2 Maneuvering Aisle Width

Where the parking space is aligned at a 90-degree angle to the maneuvering aisle, the following minimum maneuvering aisle widths, and as shown in **Figure 6**, should be satisfied.

5.2.1 Class A Passenger Loading

The required maneuvering aisle width for Class A passenger loading spaces is 6.1 m.

5.2.2 Class B Passenger Loading

The required maneuvering aisle width for Class B passenger loading spaces is 7.1 m.

5.2.3 Class C Passenger Loading

The required maneuvering aisle widths for Class C passenger loading are prescribed in [Section 7 of the Parking By-law](#).

5.2.4 Reduced Maneuvering Aisle Widths

Passenger loading spaces that are at an angle of or less than 90 degrees to the maneuvering aisle should be dimensioned as determined by the Director of Planning, in consultation with the City Engineer. For staff review, drawings should be submitted illustrating satisfactory access and egress to angles passenger loading spaces using the design vehicles as illustrated in **Table 4**.

5.3 Walls, Columns, and Side Clearance Widths

The following minimum column setbacks and side clearances, and as shown in **Figure 6**, should be satisfied for columns directly adjacent to Class B and Class C passenger spaces:

5.3.1 Class A Passenger Loading

For Class A passenger loading spaces, column encroachments are permitted per **Section 2.4 Walls, Columns, and Side Clearance Widths for Parking Spaces**. No additional side clearance width is required.

5.3.2 Class B Passenger Loading

For Class B passenger loading spaces, column encroachments are not permitted. No additional side clearance is required.

5.3.3 Class C Passenger Loading

Each Class C passenger loading space requires a minimum side clearance of 3.4 m, which may be provided on either side of the space. Except that two side-by-side Class C loading spaces may share the same 3.4 m clearance width. Column encroachments are not permitted.

5.4 Additional design considerations

- a) Where required by the Parking By-law or applicable area plan, at least one (1) Class A passenger loading space should be accommodated at-grade, accessed from the lane of all new developments to provide accessible short-term parking, pick-up and drop-off space.
- b) The maximum slope and crossfall normally permitted in a passenger loading space or access aisle is 5%.
- c) Convenient, internal, stair-free access to and from all land uses should be provided on mixed-use sites for all passenger loading spaces provided.

Table 4: Passenger Loading Design Vehicles

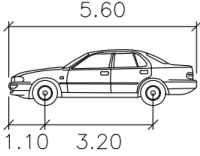
Space Classification	Design Vehicle	
Class A Passenger Loading	Passenger (P)	 <p>P</p> <p>Width : 2.00 meters Track : 2.00 Lock to Lock Time : 6.0 Steering Angle : 35.9</p>
Class B Passenger Loading	Coast Mountain Bus Company (CMBC) HandyDART	 <p>HandyDART</p> <p>Width : 2.40 meters Track : 2.40 Lock to Lock Time : 6.0 Steering Angle : 35.5</p>
Class C Passenger Loading	Intercity Bus (I-BUS)	 <p>I-BUS – Intercity Bus</p> <p>Overall Length : 14.000m Overall Width : 2.400m Overall Body Height : 3.084m Min Body Ground Clearance : 0.319m Track Width : 2.400m Lock-to-lock time : 4.00s Curb to Curb Turning Radius : 13.900m</p>

Figure 6: Passenger Loading Space Design (all dimensions in metres)

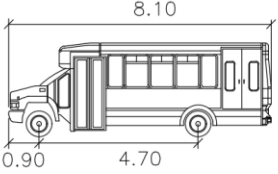
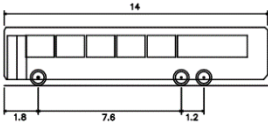
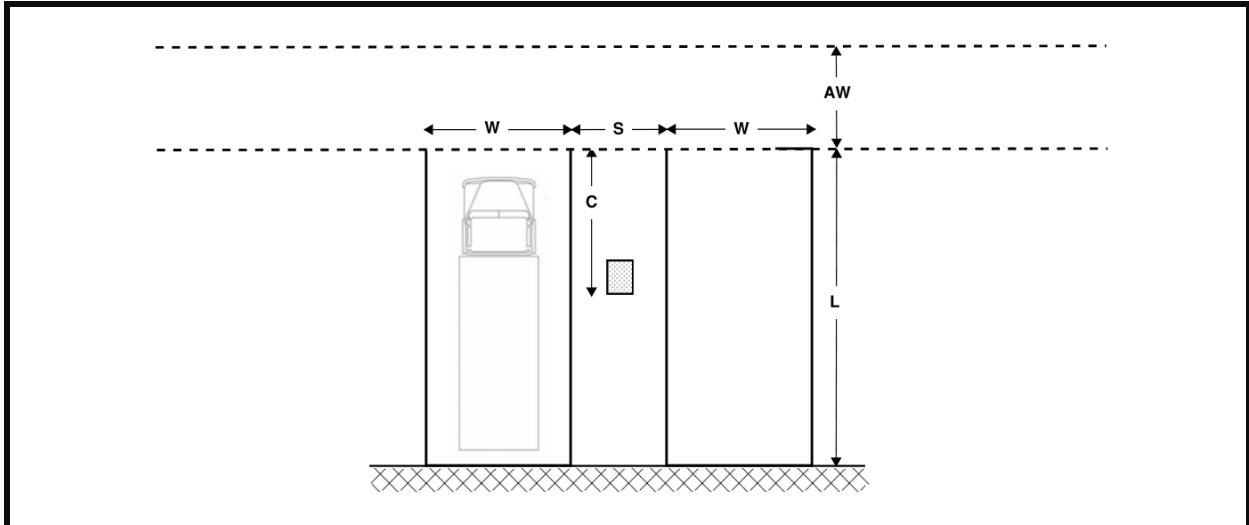

Passenger Space Classification	Aisle Width (AW)	Column Setback (C)	Side Clearance (S)	Width (W)	Length (L)
Class A	6.1	Section 2.4: Walls, Columns, and Side Clearance Widths for Parking Spaces	0.0	First space: 4.0 Additional spaces: 2.9	5.5
Class B	7.1	Column encroachments not permitted	0.0	4.0	10.5 (7.5 m space, plus 3.0 m landing area)
Class C	For spaces parallel to the lane: 3.6m For angled spaces up to and including 90 degrees, refer to 5.2.4: Reduced Maneuvering Aisle Widths	Column encroachments not permitted	0.0	First space: 3.1 Additional spaces: 4.0	14.0